

**IMPACT HEAD
DETAIL**
(2 PLACES)

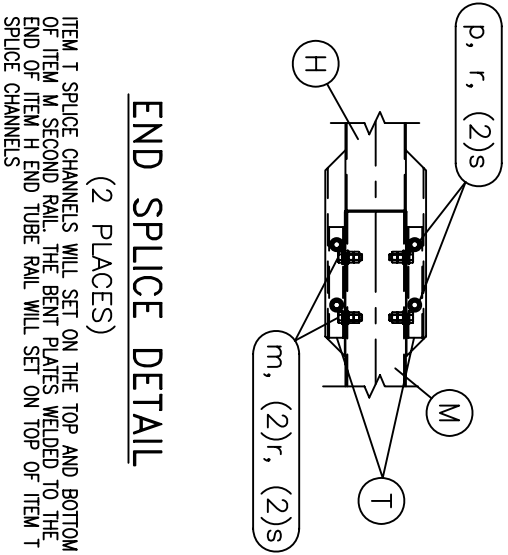

END SPLICE DETAIL
(2 PLACES)

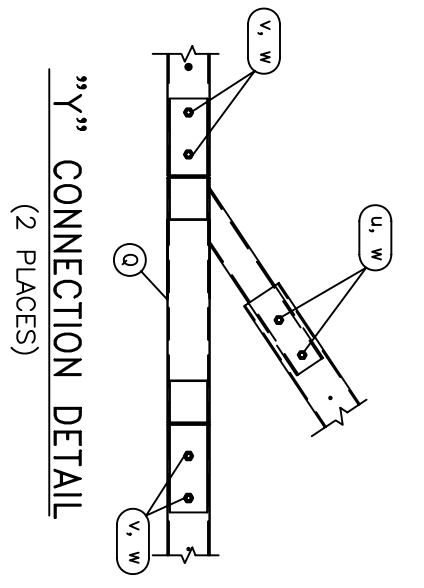

"Y" CONNECTION DETAIL
(2 PLACES)

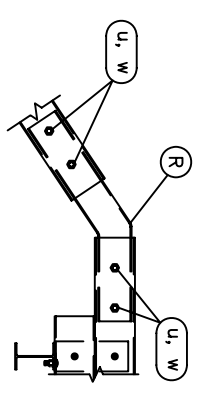

BENT SPLICE DETAIL
(2 PLACES)

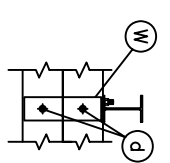

TIE PLATE DETAIL
(32 PLACES)

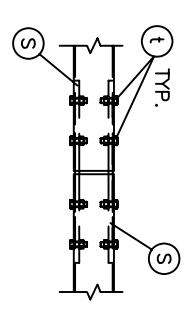

INTERNAL SPLICE DETAIL
(12 PLACES)

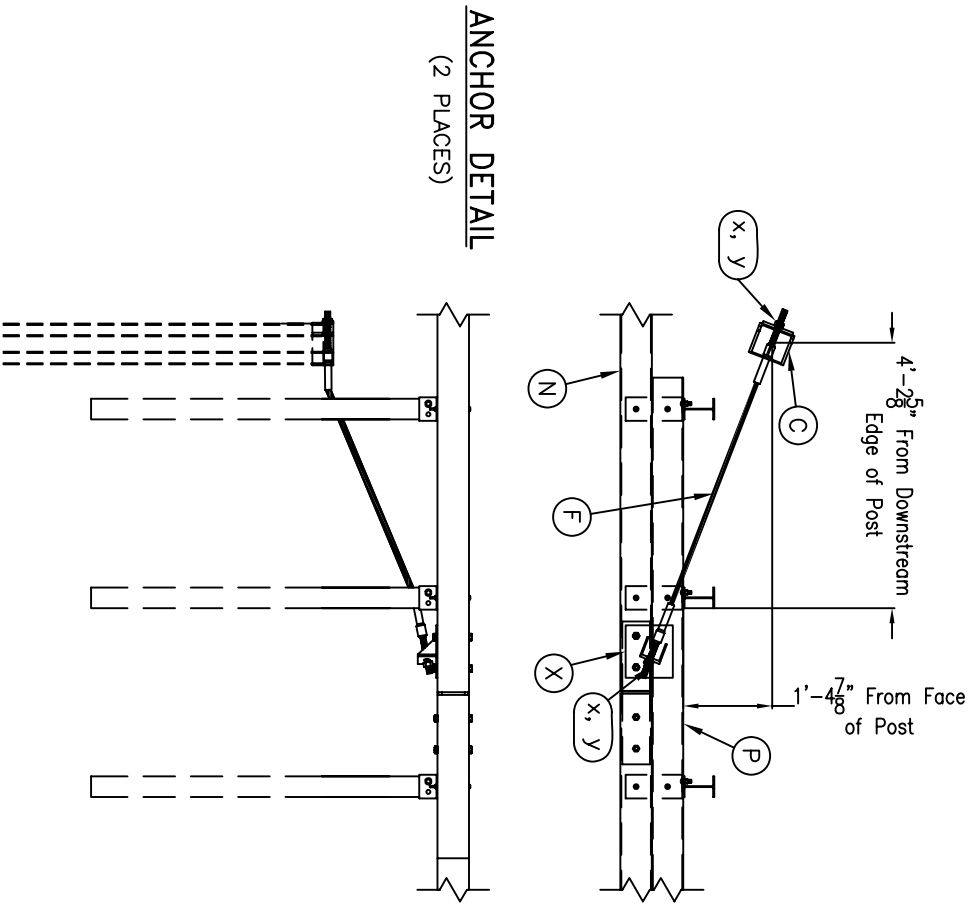

ANCHOR DETAIL
(2 PLACES)

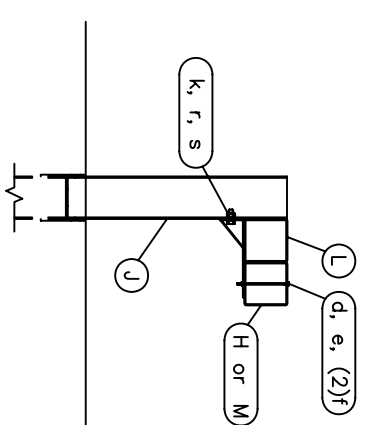

END TERMINAL POSTS
POSTS 2 THRU 6
(10 PLACES TOTAL)

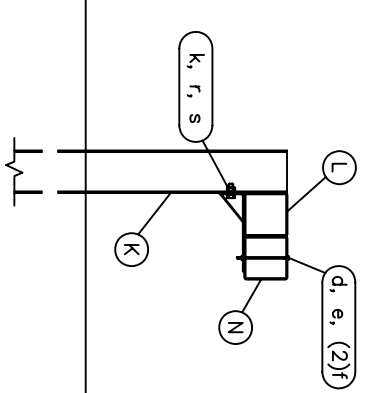

**LINE POSTS Without
Extended Block (P)**
POSTS 7-9, 14-16, 21-23, 28-30, 35-36
(28 PLACES TOTAL)

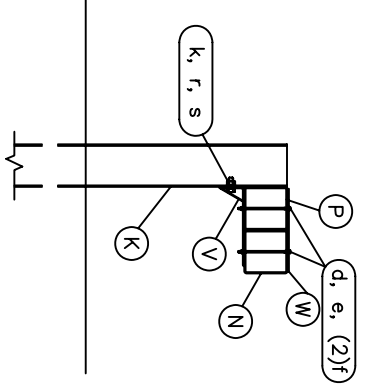

**LINE POSTS With
Extended Block (P)**
POSTS 10-13, 17-20, 24-27, 31-34
(32 PLACES TOTAL)

ITEM	QTY	DESCRIPTION
A	2	Box-Beam Impact Head
B	2	Upper End Post W6x9# x 21 1/2"
C	4	Lower End Post W6x15# x 8'-0"
D	2	Support Bracket L 4" x 2" x 4" LG.
E	2	Post Breaker Welded TS 2" x 2" x 1/4"
F	4	Cable Anchor Assembly
G	2	Cable Anchor Bearing Plate
H	2	End Tube Rail 8'-0" LG. x 1/8" THICK
J	10	Steel Breakaway Post W6x9# x 6'-0"
K	60*	Standard Steel Post W6x9# x 6'-0"
L	38*	Support Bracket TS 6" x 6" w/ Bent Pl.
M	2	Second Rail 16'-2 1/2" LG.
N	16*	BP-Rail Section 11' - 11 1/2" LG.
P	8*	Extended Block 10' LG.
Q	2	"Y" Connection
R	2	Bent Splice
S	24*	Box Beam Splice Plates w/Nuts (2 per splice)
T	4	End Section Splice Channel Bent Pl.
U	2	3/8" GALV. Cable 20' LG.
V	32*	Support Bracket
W	32*	Tie Plate
X	2	Anchor Plate
HARDWARE		
Q	2	1/4" x 3" Hex Bolt Grade 2
B	2	1/4" Hex Nut
C	4	1/4" Washer
D	104*	5/16" x 7 1/2" Hex Bolt Grade 5
E	104*	5/16" Hex Nut
F	208*	5/16" Washer
G	2	1/2" x 2" Hex Bolt Grade 2
H	2	1/2" x 5" Hex Bolt Grade 5
I	4	1/2" Hex Nut
J	4	1/2" Washer
K	70*	5/8" x 1 1/2" Hex Bolt Grade 5
M	8	5/8" x 2 1/2" Hex Bolt Grade 5
N	2	5/8" x 3" Hex Bolt Grade 5
P	8	5/8" x 6" Hex Bolt Grade 5
Q	2	5/8" x 8" Hex Bolt Grade 5
R	98*	5/8" Hex Nut
S	106*	5/8" Washer
T	96*	3/4" x 2" Hex Bolt Grade 5
U	12	3/4" x 7" Hex Bolt Grade 5
V	8	3/4" x 8" Hex Bolt Grade 5
W	20	3/4" Hex Nut
X	8	1" Hex Nut Grade 5
Y	8	1" Washer Grade 5
Z	4	Cable Tie

* QUANTITY VARIES DEPENDING ON PIER SPACING

Road Systems, Inc.
Big Spring, TX
Phone: 432-263-2435
or Phone: 350-346-0721

BEAT BRIDGE PIER
PROTECTION SYSTEM
SYSTEM DETAILS AND
PARTS LIST

Scale:
S2

Date:
05/24/06

By:
JRR