

Roadside Review

Midwest Roadside Safety Facility, University of Nebraska-Lincoln

JANUARY 2006

The Midwest Guardrail System

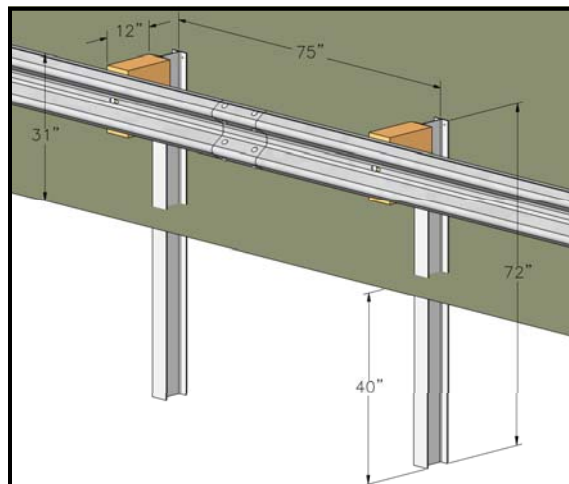

The Midwest Guardrail System (MGS) is a non-proprietary, modified W-beam guardrail system that was specifically designed for the high center of gravity vehicles found on today's roadways.

The system, developed with funding from participating states of the Midwest Pooled Fund Program, is completely generic with no patented parts, meets the NCHRP Report 350 TL-3 requirements and uses standard W-beam with a higher rail mounting height, a shallower post embedment depth, deeper blockouts, and a modified post placement scheme as compared to previous guardrail systems which have often failed to perform adequately for the larger and higher vehicles.

The standard MGS has been tested with the top of the rail as high as 32 in. and has been approved for use with a 27 5/8 in. mounting height. The taller mounting height allows for a typical 3 in. overlay without any adjustments or modifications to the guardrail.

MGS is also the first system to successfully meet the NCHRP Report 350 requirements when placed behind a 6 in. curb, and it has been successfully tested with flare

Specifics:

- 31 in. Nominal Top Rail Mounting Height
- 12 in. Blockouts
- 40 in. Embedment Depth
- Mid-Span Rail Splices
- Standard Steel or Wood 6 ft Posts
- Standard 12-Gauge W-Beam
- Non-Proprietary

Midwest Guardrail System isometric view.

rates as steep as 7:1.

An asymmetrical W-beam to thrie-beam transition has been developed for the system allowing for the connection to most thrie-beam bridge transitions. This development represents the first asymmetrical W-beam to thrie-beam transition to meet the NCHRP Report 350 requirements.

For locations where a reduced barrier deflection is required, the system has been approved with both half- and quarter-post spacing.

In addition, MGS has been successfully tested with the proposed NCHRP 350 update vehicles which are larger than the current vehicles.

To complete the package, the system has been tested successfully with three proprietary end terminals, both tangent and flared systems.

The MGS development has been reported in TRR Paper Nos. 02-3157, *Development of the Midwest Guardrail System*, and 04-4778, *Midwest Guardrail System for Standard and Special Applications*. It was also reported in the MwRSF research report no. TRP-03-139-04.



MGS full-scale crash testing with 2270P and 1100C, the proposed NCHRP 350 update vehicles.

MGS reports, papers, and drawings can be found at www.mwrsf.unl.edu



ISSUE FEATURE:

Midwest Guardrail System

INSIDE THIS ISSUE:

Midwest Guardrail System 1

MGS at 7:1 Flare Rate 2

MGS Behind 6 in. Curb 2

MGS Performance Summary 3

MGS Thrie-Beam Transition 3

MGS with 1/4 Post Spacing 3

Ongoing MGS Testing 3

Questions and Answers 4

Recent Research Reports 4

Ongoing Research 4



7:1 Flare Rate



Full-scale crash testing of the Midwest Guardrail System with a 7:1 flare rate. System performed successfully under NCHRP Report 350 test designations 3-10 and 3-11.

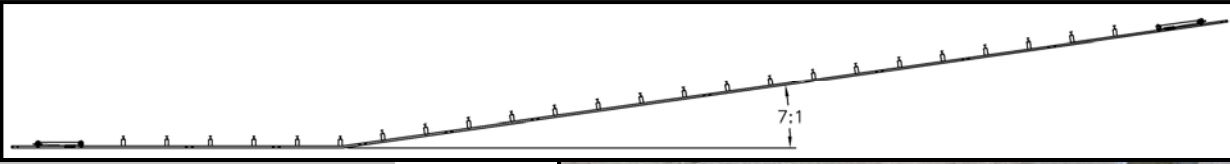

MGS Capabilities and Accomplishments:

- Top rail mounting height tolerance from 27-5/8 in. to 32 in. allows for overlays*
- Tested with flare rates as steep as 7:1 with pickup truck and small car vehicles
- Accepted with 1/2 and 1/4 span post spacing for reduced deflections*
- First and only NCHRP 350 system to be successfully tested 6 in. behind a 6 in. tall curb*
- Successful asymmetrical W-beam to thrie-beam transition
- Tested with proposed NCHRP 350 update vehicles
- Tested with both tangent and flared proprietary end terminals*
- Simple to repair as only blockouts and post bolts differ from the standard W-beam system

*FHWA acceptance letters available at <http://safety.fhwa.dot.gov/report350hardware>

6 in. Curb



Full-scale crash testing of the Midwest Guardrail System with a 6 in. curb. System performed successfully under NCHRP Report 350 test designation 3-11.

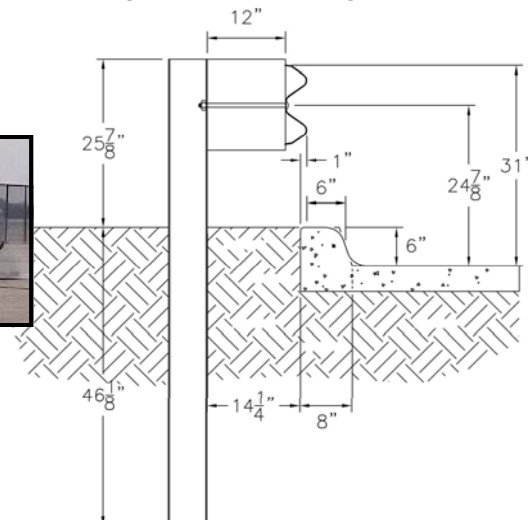

Thrie-Beam Transition

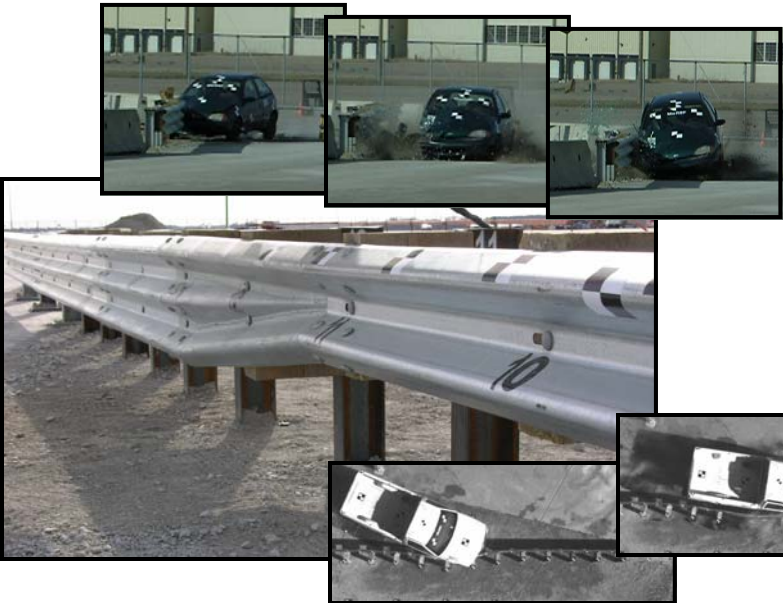

MGS Performance Summary

System	Test	Deflection (in.)	Working Width (in.)
Standard (31 in.)	3-11	43.1	49.6
32 in. Height	3-10	17.4	40.3
6 in. Curb	3-11	40.3	57.2
1/4 Post Spacing	3-11	17.6	36.7
1/2 Post Spacing	Simulation	27.8	43.1
7:1 Flare Rate	3-10	36.4	38.1
7:1 Flare Rate	3-11	75.8	87.9
Thrie-Beam Transition	3-10	12.4	33.3
Thrie-Beam Transition	3-11	23.1	40.2
Report 350 Update Proposed Vehicles			
Standard (31 in.)	3-11	43.9	48.6
32 in. Height	3-10	35.9	45.3

Full-scale crash testing of the Midwest Guardrail System with asymmetrical thrie-beam transition. System performed successfully under NCHRP Report 350 test designations 3-10 and 3-11.

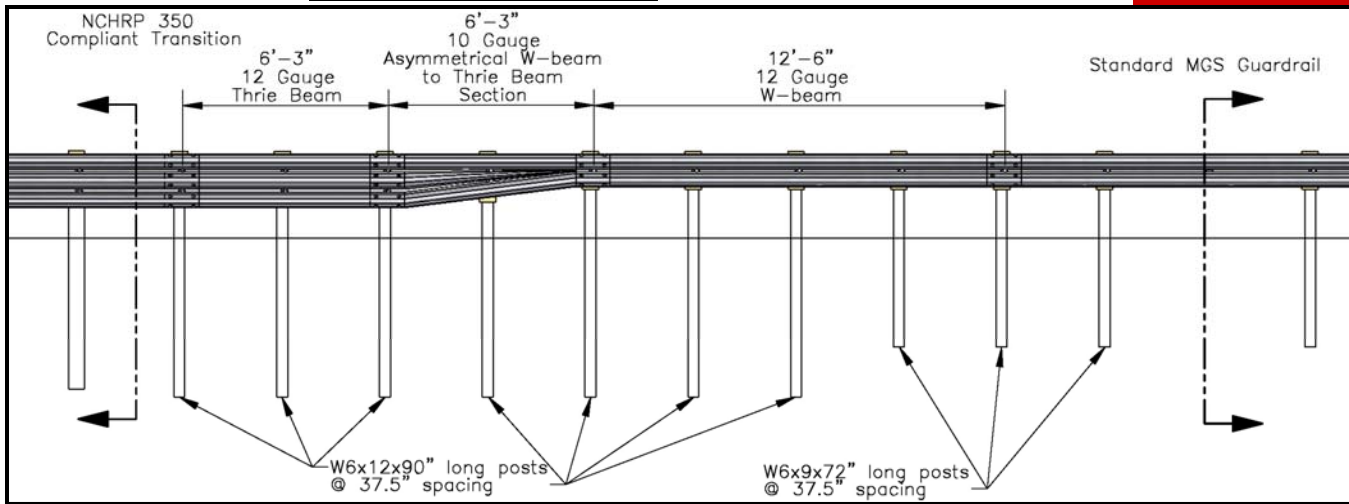

1/4 Post Spacing

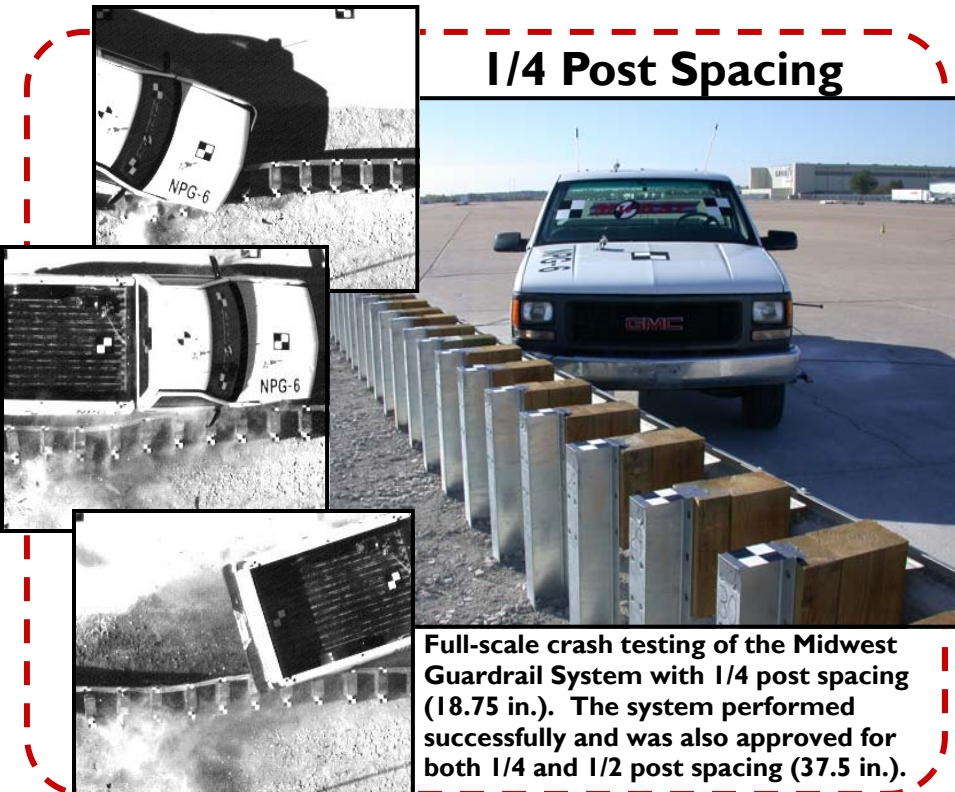

Full-scale crash testing of the Midwest Guardrail System with 1/4 post spacing (18.75 in.). The system performed successfully and was also approved for both 1/4 and 1/2 post spacing (37.5 in.).

Ongoing MGS Testing

- Long Span Design for the Midwest Guardrail System – 25' non-nested system for crossing shallow culverts.
- MGS on Breakpoint of a 2:1 Slope – Posts located on breakpoint of slope.
- Approach Slopes for W-Beam Guardrail Systems – MGS located 5' from travelway on an 8:1 slope.
- MGS utilizing small-diameter Southern Yellow Pine, Ponderosa Pine, and Douglas Fir posts.



Questions and Answers



Temporary Concrete Barrier Deflection Limits for Reduced Speeds

State Question:

What is your opinion of reducing the deflection spacing behind a temporary barrier if the speed limit is marked at lower speeds than the test speed of 62 mph? Right now we are following the criteria from your group in the deflection recommendation report of 45 in. unless used on roadways with 10 ft lanes or greater, in which case we reduce the deflection to 24 in.

MwRSF Response:

The original Iowa F-shape temporary concrete barrier was crash tested to the TL-3 criteria of NCHRP Report No. 350. In that test, dynamic barrier deflections of approximately 45 in. were observed. Later, MwRSF published a report which stated that

when the barrier is positioned near a bridge deck edge using the freestanding configuration, the clear distance between the deck edge and back-side barrier base should be 45.3 in. However, for all other applications, the design deflection limit should be set at 24 in. This distance corresponds to the distance that the Iowa temporary barrier could be expected to deflect under the 85th percentile impact for passenger cars and light trucks. The 85th percentile impact condition was determined to be a 3/4-ton pickup truck impacting at a speed of 36 mph at 27.1 degrees.



Recent Reports

- TRP-03-80-98 Crash Testing of South Dakota's Cable Guardrail System for Median Applications
- TRP-03-83-99 Guardrail and Guardrail Terminals Installed Over Curbs
- TRP-03-88-99 Development of a 7.62-m Long Span Guardrail System—Phase II
- TRP-03-99-00 Development of a W-Beam Guardrail System for Use on a 2:1 Slope
- TRP-03-119-03 Development of Standards for Placement of Steel Guardrail Posts in Rock
- TRP-03-127-03 Bridge Rails and Transition for Pedestrian Protection
- TRP-03-154-04 Dynamic Testing of Wooden Guardrail Posts—White and Red Pine Species Equivalency Study
- TRP-03-155-05 Evaluation of Alternative Cable Anchor Designs and Three-Cable Guardrail Adjacent to Steep Slope
- TRP-03-126-03 Embankment Widening and Slopes Required for Gating-Type End Terminals

*Check out the publications section of Midwest Roadside Safety Facility website to request copies of the reports

Ongoing Research

- Development of a Guardrail Treatment at Intersecting Roadways – Short radius guardrail system.
- Evaluation of Rigid Hazards in Zone of Intrusion – Rigid poles mounted on top of and behind rigid barriers.
- Three-Cable Guardrail In Front of Slope – Will utilize a 48" offset from a 1.5:1 slope and a 4' post spacing.
- Development of a Four-Strand, High-Performance Cable Barrier – Tensioned, non-proprietary system to be tested in a depressed median.
- Evaluation of Transverse Culvert Safety Gate – Full-scale test of 20'x20' culvert grate on 3:1 slope.
- New TL-5 Median Barrier and Anchor – Concrete median barrier.
- Cost Effective Measures for Roadside Design on Low Volume Roads.
- Termination of Temporary Concrete Barrier – Develop anchorage and run L.O.N. test.



Zone of Intrusion Study

- Develop Temporary Concrete Barrier Transition – Transition to permanent and/or other longitudinal barrier.
- Evaluation of the Safety Performance of Vertical and Safety Shaped Concrete Barriers.

