

Assembly Instructions for

SKT-SP Tangent Terminal
&
FLEAT-SP Flared Terminal

SP – Standard Post System Guardrail Terminals



ROAD SYSTEMS, INC.

P. O. Box 2163

Big Spring, Texas 79721

Phone: (432) 263-2435 FAX: (432) 267-4039

Technical Support & Marketing Phone: (330) 346-0721

Technical Support & Marketing Fax: (330) 346-0722

All RSI Installation Manuals can be downloaded from RSI web site

www.roadsystems.com

Table of Contents

	<u>Page</u>
General Information SKT-SP & FLEAT-SP Designs.....	2-3
SKT & FLEAT Design Options	4-5
Begin Assembly – Drawing & Photo Details	6
Bill of Materials for SKT-SP	6
Plan and Elevation View of SKT-SP System / Figure 1	7
Optional Flared Installation for SKT-SP / Figure 2	8
Bill of Materials for FLEAT-SP	9
Plan and Elevation View of FLEAT-SP System / Figure 3	10
View of SKT-SP End Post #1 / Figure 4	11
View of FLEAT-SP End Post #1 / Figure 5	12
Post #1 Connection Detail for SKT-SP & FLEAT-SP / Figure 6	13
Post #2 Connection Detail for SKT-SP & FLEAT-SP / Figure 7	14
Installation of Cable Anchor Bracket Shoulder Bolts / Figure 8	15
Installation of Cable Anchor Bracket for SKT-SP & FLEAT-SP / Figure 9 ...	15
Impact Head Connection for SKT-SP & FLEAT-SP / Figure 10	16
Grading Recommendations for SKT-SP / Figure 11	17
Grading Recommendations for FLEAT-SP / Figure 12	18
Installing the SKT-SP & FLEAT-SP	19
Materials	19
Site Preparation	19
Tools Required	19
Installation Procedures	19
Installing Standard Steel Guardrail Posts #3 and Beyond	20
Installing Breakaway Steel End Posts #1 and #2.....	20
Installing Guardrail	21
Installing Cable Anchor Bracket.....	21
Installing SKT-SP or FLEAT-SP Impact Head.....	22
Installing Cable Assembly	22
Inspection Checklist for SKT-SP & FLEAT-SP	23
Repairing the SKT-SP & FLEAT-SP	24

General Information

For **SKT-SP** & **FLEAT-SP**

Steel Post Designs

The **SKT-SP** & **FLEAT-SP** were crash tested to meet the requirements of NCHRP Report 350 Test Level 3 (100 km/hr) and Test Level 2 (70 km/hr). Refer to specific State DOT standards and specifications for allowable design alternatives. It is the responsibility of the installer to utilize a design approved by the State DOT and to follow all required State procedures in installing the **SKT-SP** and **FLEAT-SP**.

This Installation Manual is divided into 6 sections

- General Information for **SKT-SP** & **FLEAT-SP** Steel Post Designs.
- **SKT** & **FLEAT** Design Options – This area describes the many different post options (steel and wood posts) to choose from for the SKT & FLEAT. (pages 4 - 5)
- **SKT-SP** & **FLEAT-SP** Drawing & Photo Details – This area shows a bill of materials and assembly details for the SKT-SP and FLEAT-SP. (pages 6 - 18)
- Installing the **SKT-SP** & **FLEAT-SP** – This section gives a step-by-step procedure on the proper assembly of SKT-SP & FLEAT-SP Standard Post systems. (pages 19 - 22)
- Inspection Checklist for **SKT-SP** & **FLEAT-SP** – Use the checklist to inspect new installations or recently maintained/repaired installations. (page 23)
- Repairing the **SKT-SP** & **FLEAT-SP** – This section gives general repair procedures for the SKT-SP & FLEAT-SP Standard Post systems. (page 24)

The Following Pay Limit Lengths are accepted for use with the SKT-SP

Measurement and payment shall be for each **SKT-SP** Standard Post Guardrail End Treatment measured complete and in place as shown in the installation instructions and on the contract plans. The pay limit options may be as shown below:

- 12.5 ft – **Hinged Posts #1 & #2**. Posts #3 - #7 shall be W6x9# x 6'-0" standard guardrail posts (for a TL-3 system). This has a 12.5 ft pay limit.
- 25 ft – **Hinged Posts #1 & #2**. Posts #3 - #7 shall be W6x9# x 6'-0" standard guardrail posts (for a TL-3 system). If this is a TL-2 (70 km/h - 43 mph), requires 5 total posts.
- 37.5 ft – **Hinged Posts #1 & #2**. Posts #3 - #7 shall be W6x9# x 6'-0" standard guardrail posts.
- 50 ft – **Hinged Posts #1 & #2**. Posts #3 - #8 shall be W6x9# x 6'-0" standard guardrail posts. This is a TL-3 system and has a 50 ft pay limit.

If the **SKT-SP** is designed to attach to a rigid barrier, a transition to gradually increase the stiffness in the W-Beam shall be required. The terminal would have a length of 50'-0" for TL-3 applications.

Check the State standard sheets or contract plans to see which option is approved in your State.

General Information (continued)

The **SKT-SP** is a tangent terminal and no offset is required. However to avoid nuisance impacts, a straight flare offset of 1-ft but no more than 2-ft is recommended over a 50 ft length. For TL-2 applications, the flare rate is the same and the allowable offset is variable anywhere between zero and 1-ft over a 25 ft length. Design, selection & placement of the **SKT-SP** system shall conform to the *AASHTO Roadside Design Guide* and the details shown on the contract plans. The assembly of the **SKT-SP** shall be in accordance with the recommendations of Road Systems, Inc.

The Following Pay Limit Lengths are accepted for use with the FLEAT-SP

Measurement and payment shall be for each **FLEAT-SP** Standard Post Guardrail End Treatment measured complete and in place as shown in the installation instructions and on the contract plans. The pay limit options may be as shown below:

- 12.5 ft – **Hinged Posts #1 & #2**. Posts #3 - #7 shall be W6x9# x 6'-0" standard guardrail posts (for a TL-3 system). This has a 12.5 ft pay limit.
- 25 ft – **Hinged Posts #1 & #2**. Posts #3 - #7 shall be W6x9# x 6'-0" standard guardrail posts (for a TL-3 system). If this is a TL-2 (70 km/h - 43 mph), requires 5 total posts.
- 37.5 ft – **Hinged Posts #1 & #2**. Posts #3 - #7 shall be W6x9# x 6'-0" standard guardrail posts.

If the **FLEAT-SP** is designed to attach to a rigid barrier, a transition to gradually increase the stiffness in the W-Beam shall be required. The terminal would have a length of 37'-6" for TL-3 applications.

Check the State standard sheets or contract plans to see which option is approved in your State.

The **FLEAT-SP** shall be installed on a straight flare. The allowable offset is variable anywhere between 2.5-ft and 4-ft over a 37.5 ft length. For TL-2 applications, the flare rate is the same and the allowable offset is variable anywhere between 1'-8" and 2'-8" over a 25 ft length. Design, selection and placement of the **FLEAT-SP** system shall conform to the *AASHTO Roadside Design Guide* and the details shown on the contract plans. The assembly of the **FLEAT-SP** shall be in accordance with the recommendations of Road Systems, Inc.

NOTE: Anywhere a W6x9# x 6'-0" standard guardrail post is mentioned throughout this manual, a W6x8.5# x 6'-0" standard guardrail post is equivalent and is permitted.

SKT & FLEAT Design Options

There are many different support post options available for the SKT & FLEAT as shown below.

<u>SKT or FLEAT Support Post Design Options</u>	Number of Bolted Hinged Steel Posts	Number of Standard Steel Guardrail Posts	Number of Plug Weld Steel Posts	Number of Wood BCT Posts 3'-9" long	Number of Wood CRT Posts 6'-0" long	Number of Foundation Tubes
SKT-SP & FLEAT-SP Standard Steel Guardrail Post System	SKT - 2 FLEAT - 2 <u>Post #1 is 6" x 6" Tube w/ W6x15# lower post</u> <u>Post #2 is W6x9# Post w/W6x9# lower post</u>	SKT - 6 FLEAT - 5	- 0 -	- 0 -	- 0 -	- 0 -
All Hinged Steel Post System	SKT - 2 long, 6 medium FLEAT - 2 long, 5 medium	- 0 -	- 0 -	- 0 -	- 0 -	- 0 -
All Plug Weld Steel Post System	- 0 -	- 0 -	SKT - 2 short, 6 medium FLEAT - 2 short, 5 medium	- 0 -	- 0 -	SKT - 2 FLEAT - 2
Hinged & Plug Weld Steel Post System	SKT - 2 long FLEAT - 2 long	- 0 -	SKT - 6 medium FLEAT - 5 medium	- 0 -	- 0 -	- 0 -
Hinged Steel & Wood Post System	SKT - 2 long FLEAT - 2 long	- 0 -	- 0 -	- 0 -	SKT - 6 FLEAT - 5	- 0 -
All Breakaway Wood Post System	- 0 -	- 0 -	- 0 -	SKT - 2, 4 or 8 FLEAT - 2 only	SKT - 6, 4 or 0 FLEAT - 5 only	SKT - 2, 4 or 8 FLEAT - 2 only

NOTE: The above is based on a 50'-0" long SKT system and a 37'-6" long FLEAT system.

See next page for the approximate lengths of the posts that are shown in the above table.

Refer to other Wood Post & Steel Post Installation Manuals for additional information on installation of SKT & FLEAT other than "SP" Standard Post option.

SKT & FLEAT Design Options (continued)

Post Lengths & Descriptions: Shown below are the different posts identified in the table on the previous page. The approximate lengths of posts that are shown are for reference only and are for the purpose of identifying a general length relative to the other posts. These post lengths may not be an exact length.

- **Standard Steel Guardrail Posts** are used for the **SKT-SP** and **FLEAT-SP**. They are W6x9# or W6x8.5# and are 6'-0" long.
- **BCT Wood Posts** are 5 ½" x 7 ½" x 3'-9" long having (1) breakaway hole and they are inserted in a steel foundation tube.
- **CRT Wood Posts** are 6" x 8" x 6'-0" long and have (2) breakaway holes.
- **Long Hinged Steel Posts** are approximately 8.5 feet long and must be bolted together in the field.
- **Medium Hinged Steel Posts** are 6 feet long and must be bolted together in the field.
- **Medium Plug Weld Steel Posts** are 6 feet long and are shipped as a welded assembly.
- **Short Plug Weld Steel Posts** are approximately 3.5 feet long and inserted in a foundation tube. They are shipped as a welded assembly.
- **Steel Foundation Tubes** at post locations #1 & #2 may be either 6 feet long (no soil plate needed) or 4.5 feet or 5 feet long (with a soil plate). When foundation tubes are used at post locations #3 and beyond (for the SKT only) they are 4.5 feet long and do not require soil plates.

Begin Assembly – Drawing & Photo Details

ITEM	QTY	BILL OF MATERIALS	ITEM NO.
A	1	IMPACT HEAD	S3000
B	1	W-BEAM GUARDRAIL END SECTION, 12 Ga.	SF1303
C	1	FIRST POST TOP (6X6X $\frac{1}{8}$ " Tube)	TPHP1A
D	1	FIRST POST BOTTOM (6' W6X15)	TPHP1B
E	1	SECOND POST ASSEMBLY TOP	HP2A
F	1	SECOND POST ASSEMBLY BOTTOM	HP3B
G	1	BEARING PLATE	E750
H	1	CABLE ANCHOR BOX	S760
J	1	BCT CABLE ANCHOR ASSEMBLY	E770
HARDWARE (ALL DIMENSIONS IN INCHES)			
a	2	5/16 x 1 HEX BOLT GRD 5	B5160104A
b	4	5/16 WASHER	W0516
c	2	5/16 HEX NUT	N0516
d	9	5/8 Dia. x 1 1/4 SPLICE BOLT (POST #2)	B580122
e	1	5/8 Dia. x 9 HEX BOLT GRD 5	B580904A
f	3	5/8 WASHER	W050
g	10	5/8 Dia. H.G.R NUT	N050
h	1	3/4 Dia. x 8 1/2 HEX BOLT GRD A449	B340854A
j	1	3/4 Dia. HEX NUT	N030
k	2	1 ANCHOR CABLE HEX NUT	N100
l	2	1 ANCHOR CABLE WASHER	W100
m	8	CABLE ANCHOR BOX SHOULDER BOLT	SB58A
n	8	1/2 A325 STRUCTURAL NUT	N055A
o	16	1 1/16 OD x 9/16 ID A325 STR. WASHER	W050A

Post #3 and beyond are W6 x 9# or W6 x 8.5# x 6'-0" long standard steel guardrail posts.

Note that a ground strut is not used with the SKT-SP system.

Bill of Materials for SKT-SP (NOTE: 12'-6" Pay Limit shown)

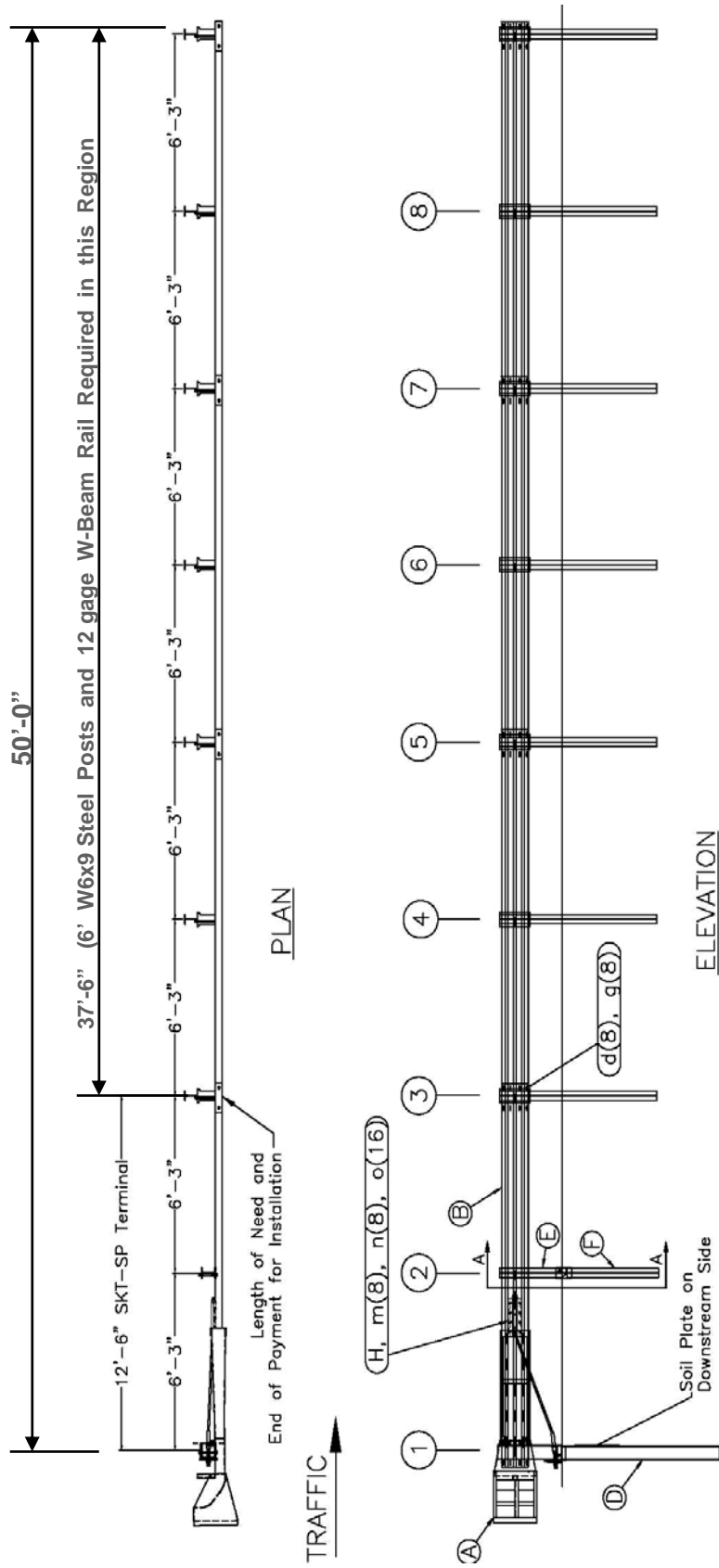
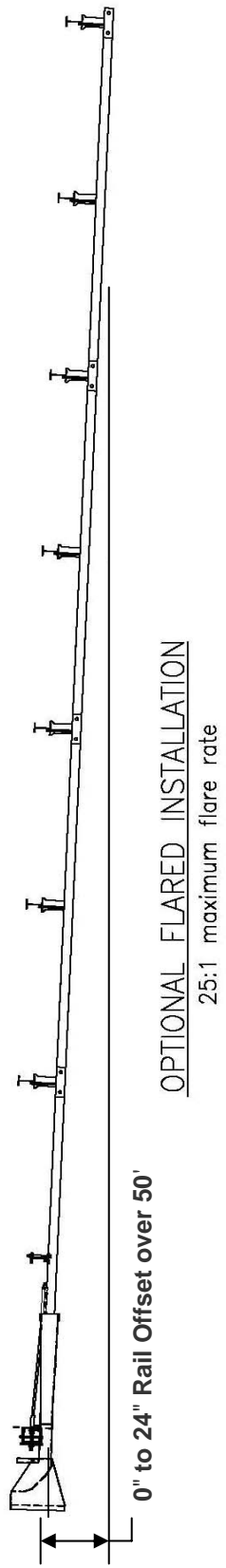

Figure 1. Plan and Elevation View of **SKT-SP** Standard Post System



Impact Head Feeder Guide Chute



Impact Head delineated with object marker

Figure 2. Optional Flared Installation for SKT-SP

TEM	QTY	BILL OF MATERIALS	ITEM NO.
A	1	IMPACT HEAD	F3000
B	1	W-BEAM GUARDRAIL END SECTION, 12 Ga.	SF1303
C	1	FIRST POST TOP (6X6X $\frac{1}{8}$ " Tube)	TPHP1A
D	1	FIRST POST BOTTOM (6' W6X15)	TPHP1B
E	1	SECOND POST ASSEMBLY TOP	HP2A
F	1	SECOND POST ASSEMBLY BOTTOM	HP3B
G	1	BEARING PLATE	E750
H	1	CABLE ANCHOR BOX	S760
J	1	BCT CABLE ANCHOR ASSEMBLY	E770
HARDWARE (ALL DIMENSIONS IN INCHES)			
a	2	5/16 x 1 HEX BOLT GRD 5	B5160104A
b	4	5/16 WASHER	W0516
c	2	5/16 HEX NUT	N0516
d	9	5/8 Dia. x 1 1/4 SPLICE BOLT (POST #2)	B580122
e	1	5/8 Dia. x 9 HEX BOLT GRD 5	B580904A
f	3	5/8 WASHER	W050
g	10	5/8 Dia. H.G.R NUT	N050
h	1	3/4 Dia. x 8 1/2 HEX BOLT GRD A449	B340854A
j	1	3/4 Dia. HEX NUT	N030
k	2	1 ANCHOR CABLE HEX NUT	N100
l	2	1 ANCHOR CABLE WASHER	W100
m	8	CABLE ANCHOR BOX SHOULDER BOLT	SB58A
n	8	1/2 A325 STRUCTURAL NUT	N055A
o	16	1 1/16 OD x 9/16 ID A325 STR. WASHER	W050A

Post #3 and beyond are W6 x 9# or W6 x 8.5# x 6'-0" long standard steel guardrail posts.
Note that a ground strut is not used with the FLEAT-SP system.

Bill of Materials for FLEAT-SP (NOTE: 12'-6" Pay Limit shown)

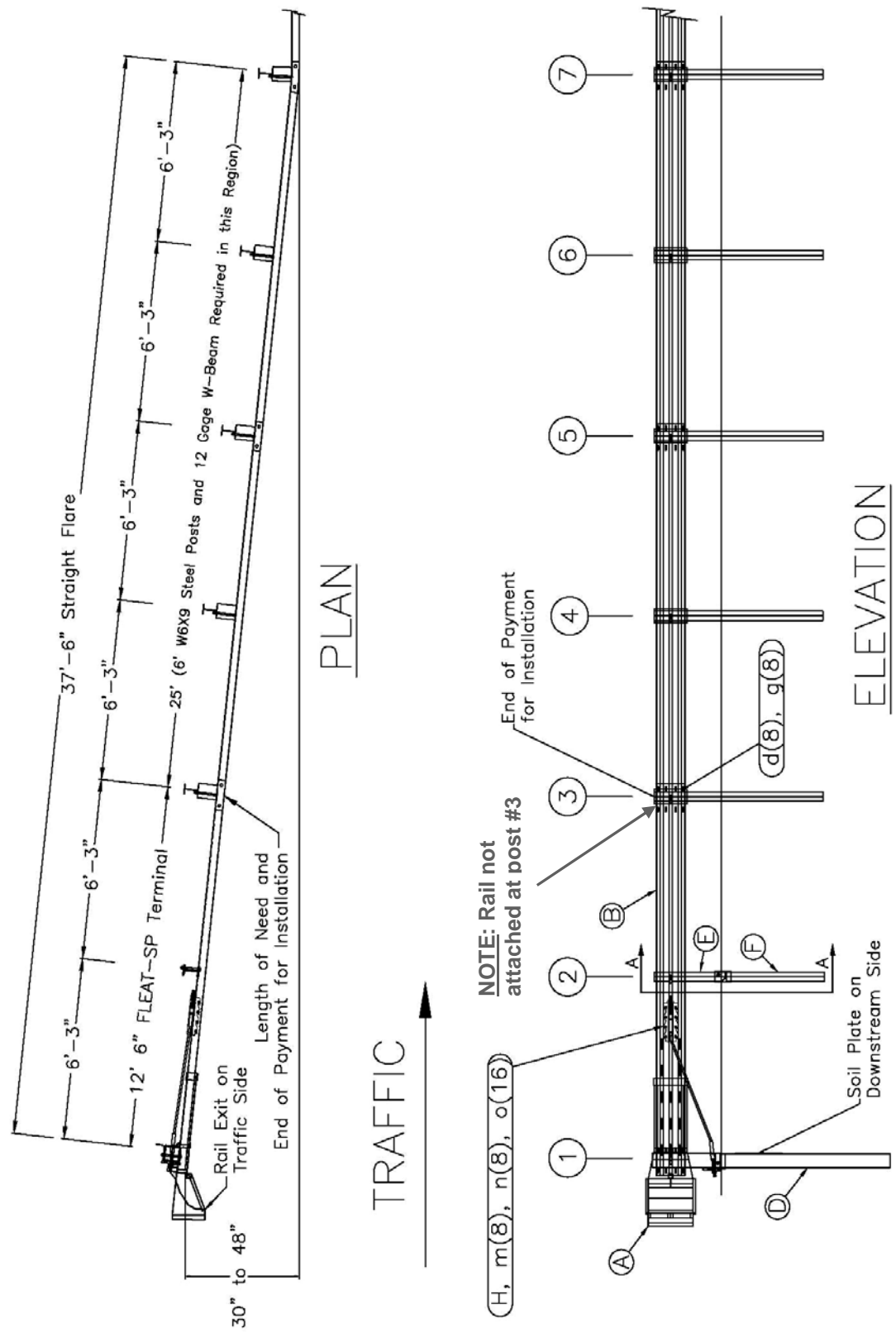
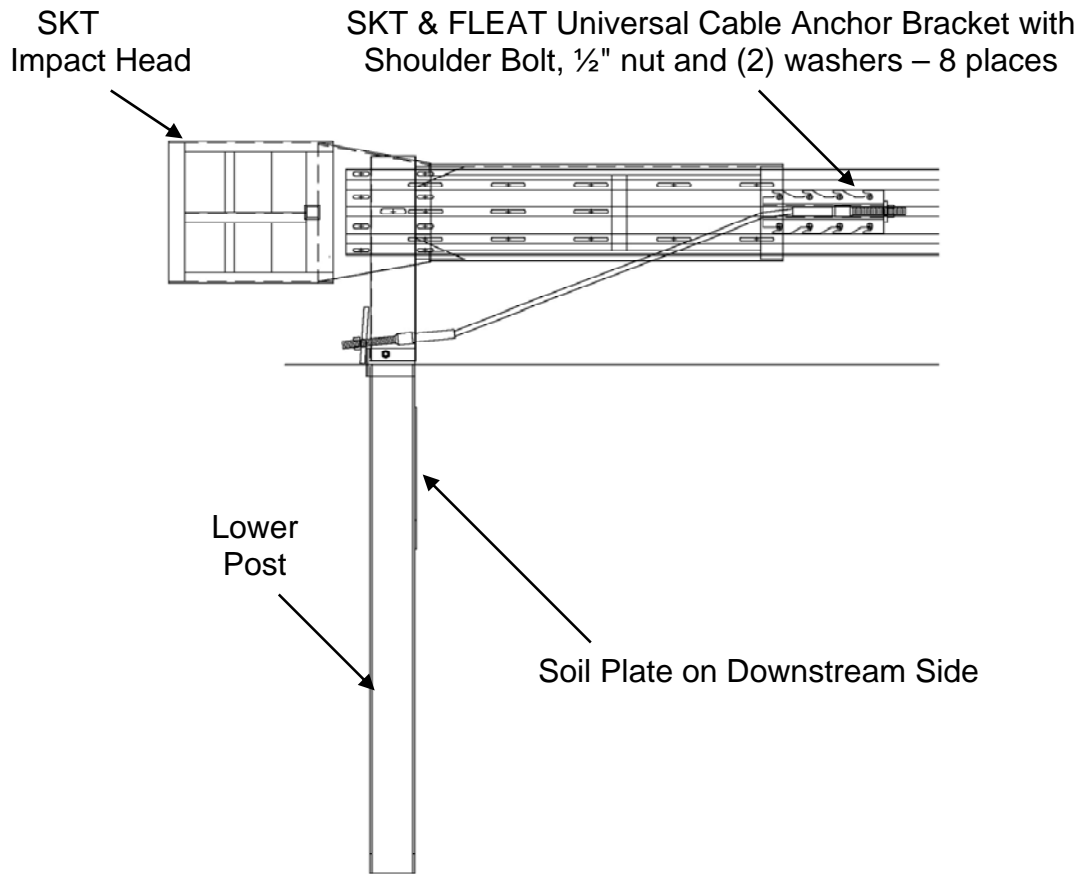
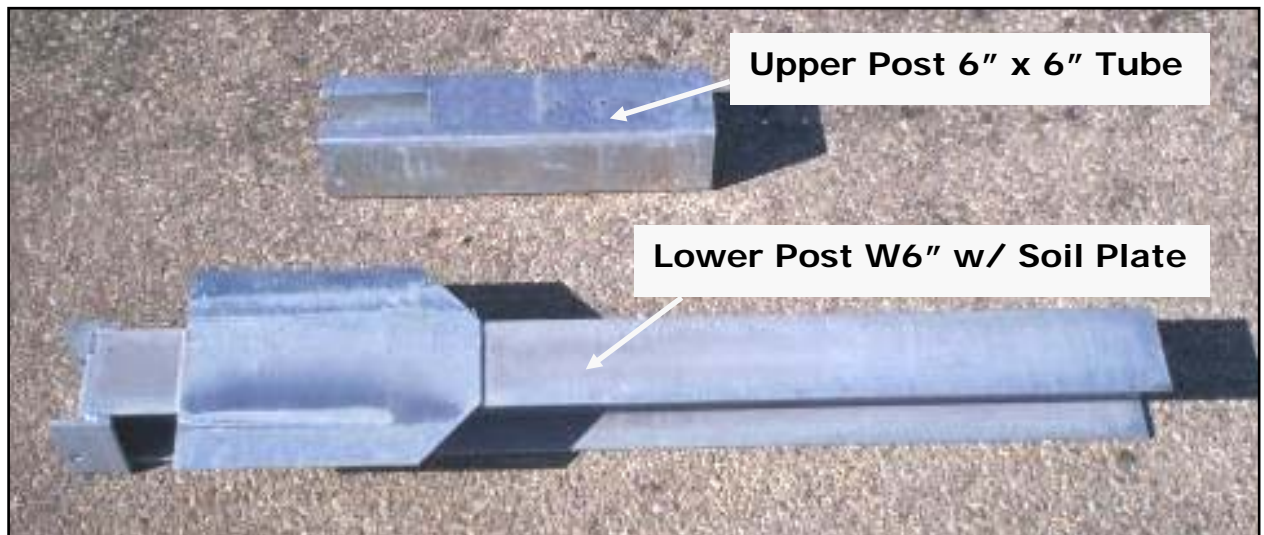

Figure 3. Plan and Elevation View of **FLEAT-SP** Standard Post System



NOTE: Be sure the 5/8" x 9" hex bolt at Hinged Post #1 is on the upstream side of the post.



NOTE: The upper and lower posts are used for both the SKT-SP and FLEAT-SP

Figure 4. View of SKT-SP Steel End Post #1

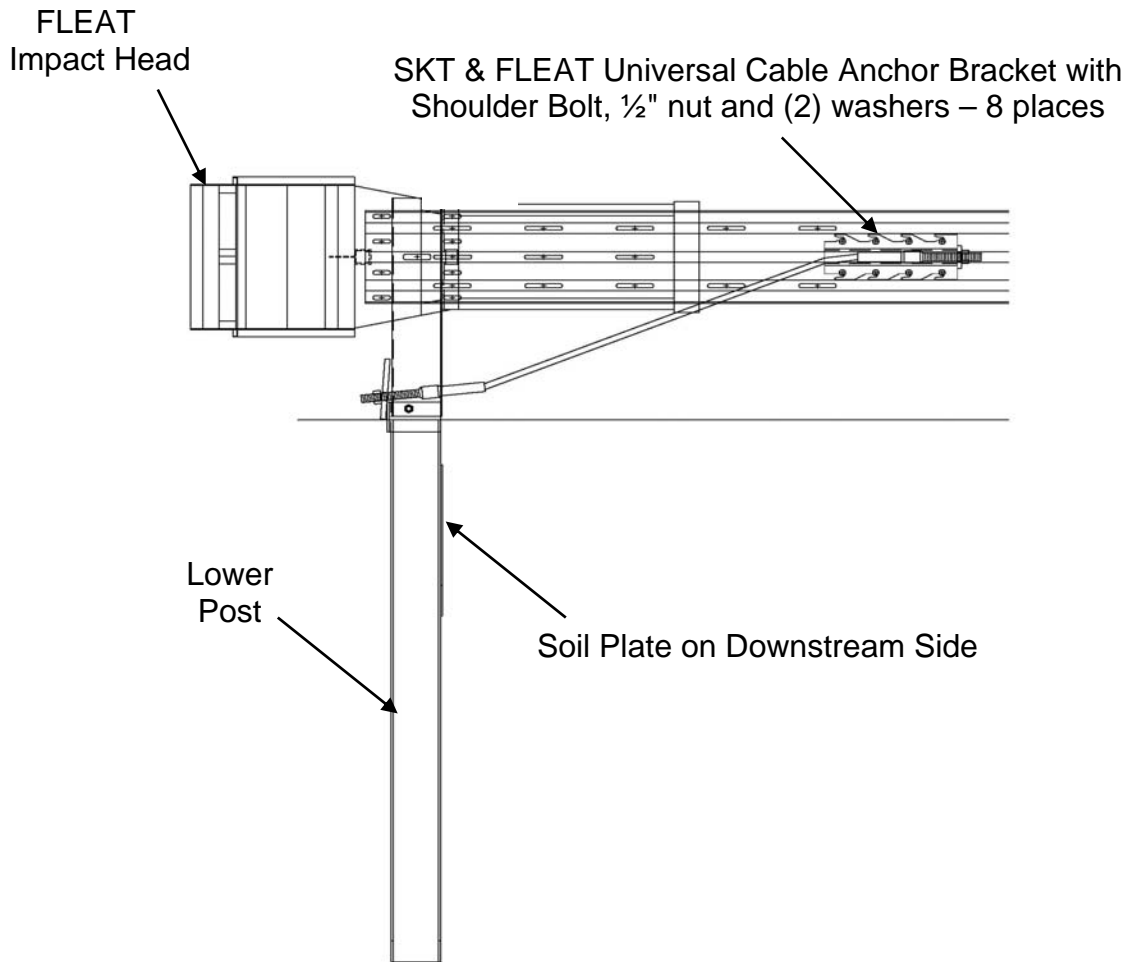

NOTE: Be sure the 5/8" x 9" hex bolt at Hinged Post #1 is on the upstream side of the post.



Figure 5. View of FLEAT-SP Steel End Post #1



(Note that retainer / tie to keep bearing plate from rotating is not shown in this photo.)

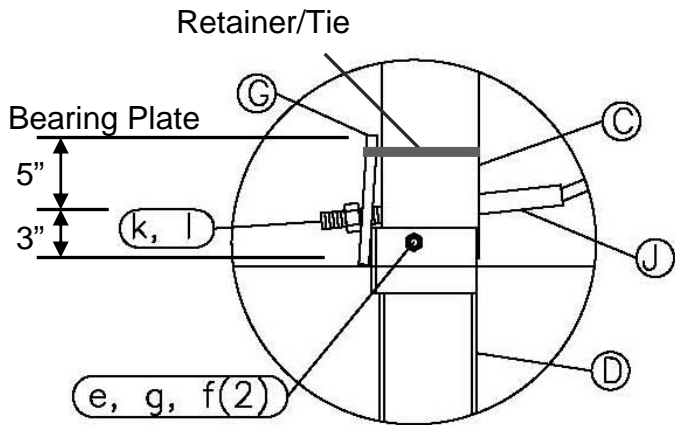

C	Upper Post #1 Tube 6" x 6"
D	Lower Post #1 W6" with Soil Plate
G	Bearing Plate & Retailer/Tie
J	Cable Anchor Assembly
e	5/8" x 9" Hex Bolt
f	5/8" Washer
g	5/8" Nut
k	1" Nut
l	1" Washer

(SKT-SP shown. FLEAT-SP details similar.)

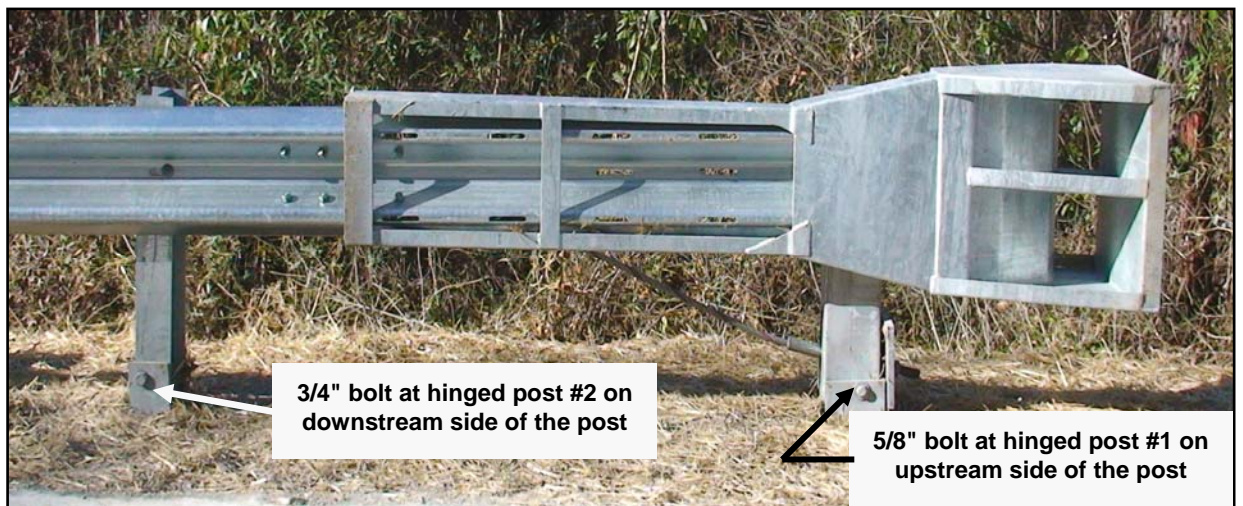
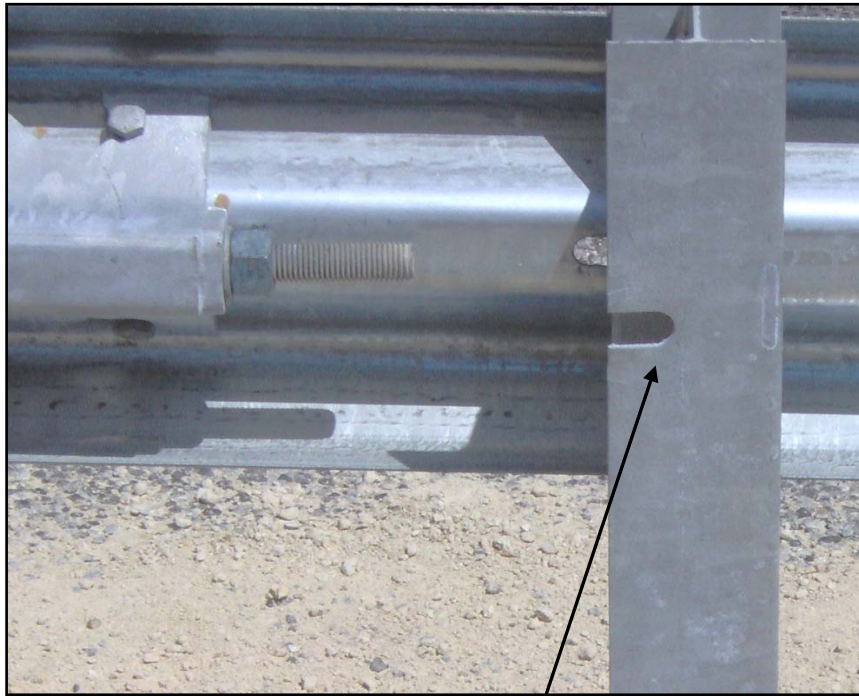
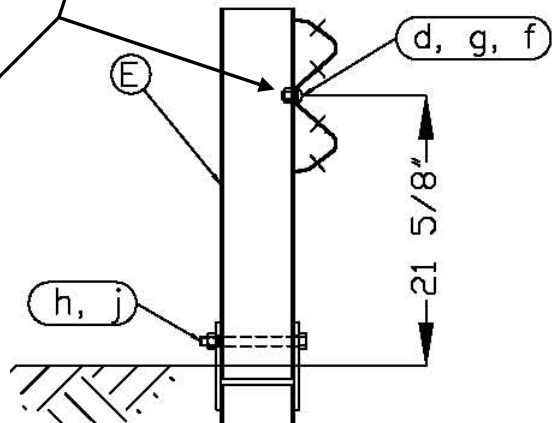

Figure 6. Post #1 Connection Detail for SKT-SP & FLEAT-SP



There is an open-ended slot in the flange of the post at the post bolt connection. Be sure upper post #2 is installed with this slot facing post #1.



E	Upper Post #2 W6"
d	5/8" x 1 1/4" Guardrail Splice Bolt
f	5/8" Washer
g	5/8" Nut
h	3/4" x 8 1/2" Hex Bolt
j	3/4" Nut

NOTE: Be sure the 3/4" x 8 1/2" hex bolt at Hinged Post #2 is on the downstream side of the post (toward post #3).

Figure 7. Post #2 Detail for SKT-SP & FLEAT-SP

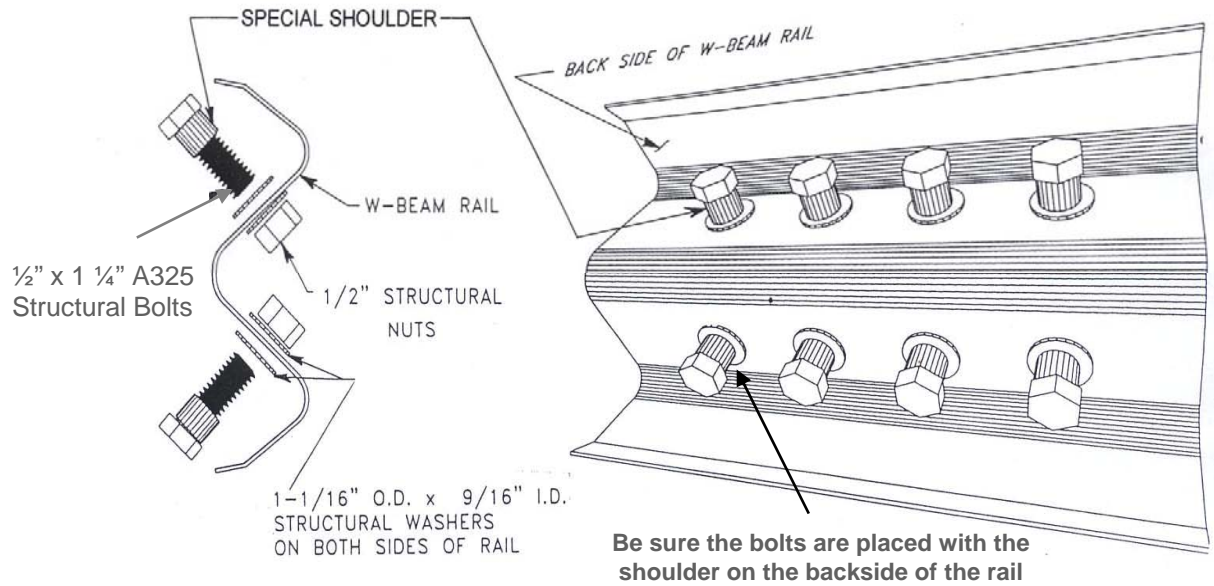
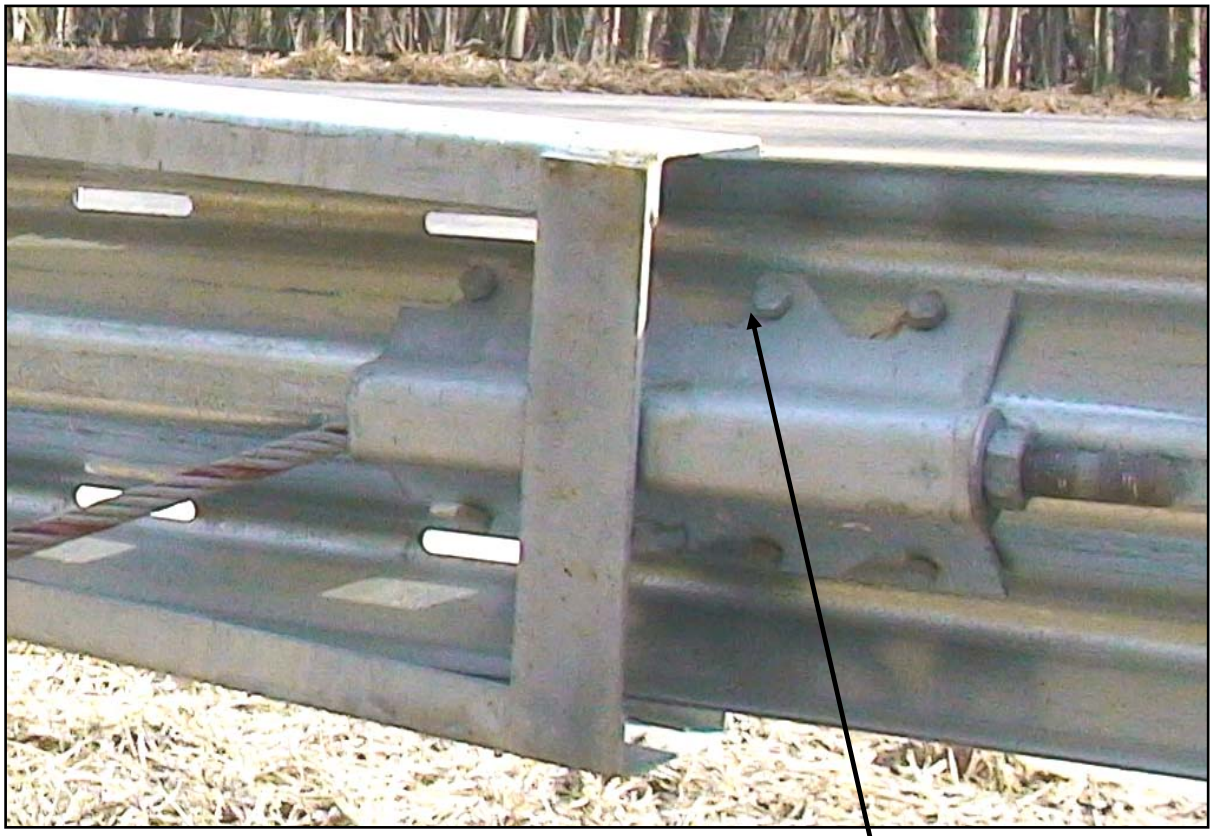

Figure 8. Installation of Cable Anchor Bracket Shoulder Bolts



It is important that the anchor bracket be fully seated on the shoulder portion of the cable anchor bolts

Figure 9. Installation of Cable Anchor Bracket for SKT-SP & FLEAT-SP



(SKT-SP shown. FLEAT-SP details similar.)

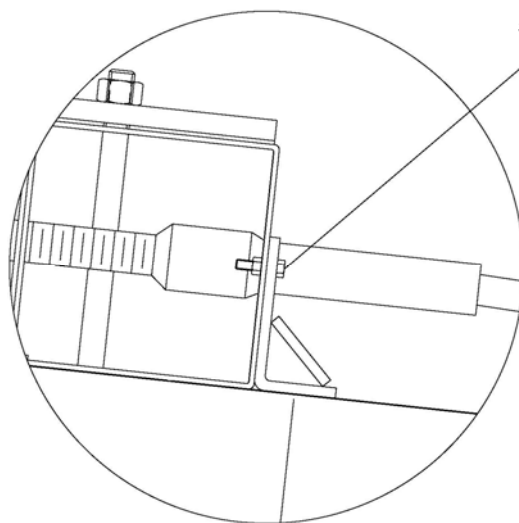

5/16" x 1" hex bolt w/ nut &
(2) washers – 2 places

Figure 10. Impact Head Connection Detail for SKT-SP & FLEAT-SP

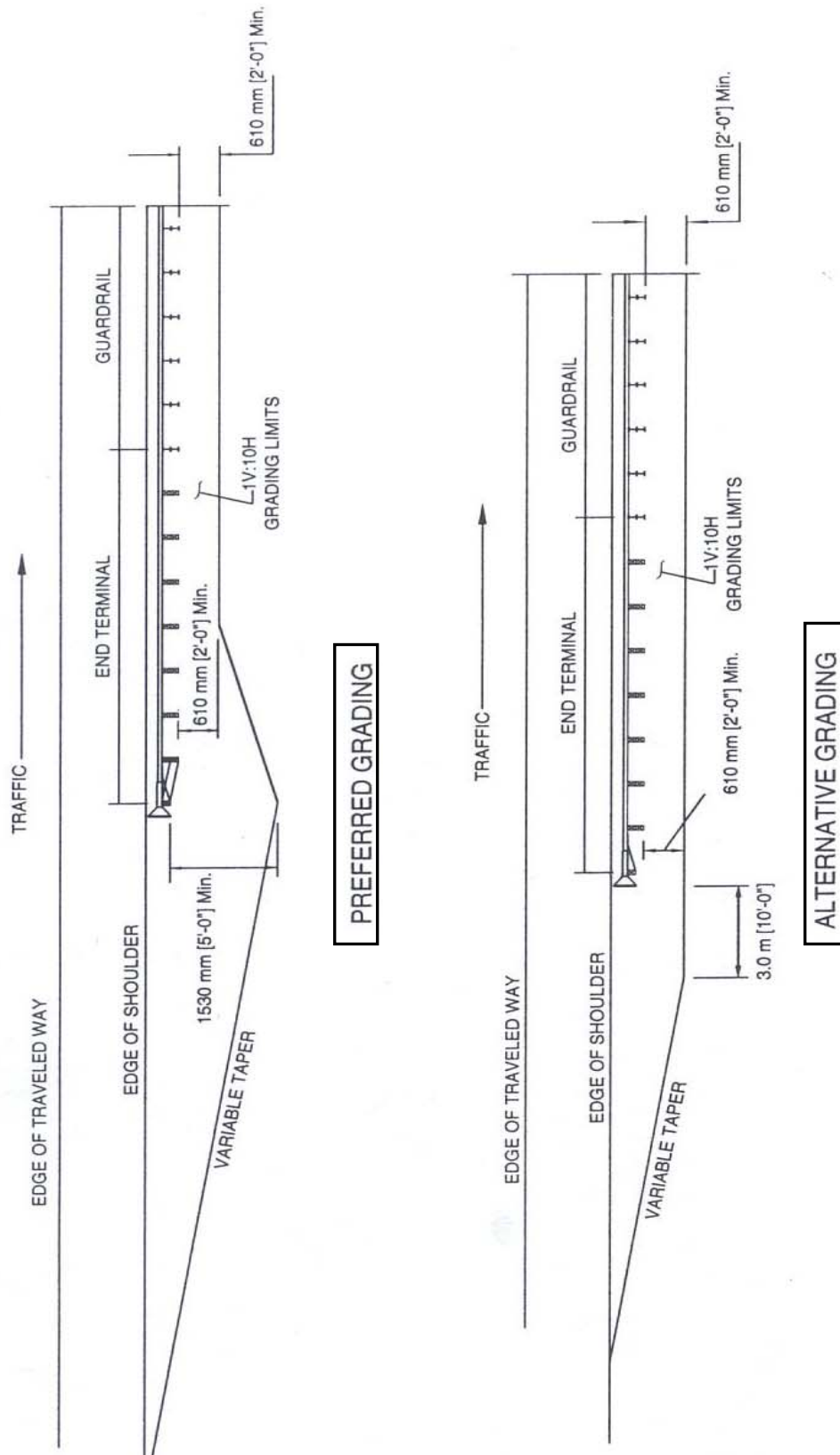

(Reference AASHTO Roadside Design Guide)

Figure 11. Grading Recommendations for **SKT-SP**

*The preferred grading layout should be used wherever practical. However, because of site limitations, when upgrading an existing terminal with a crashworthy terminal meeting NCHRP Report 350 criteria, the alternative grading layout may be used.

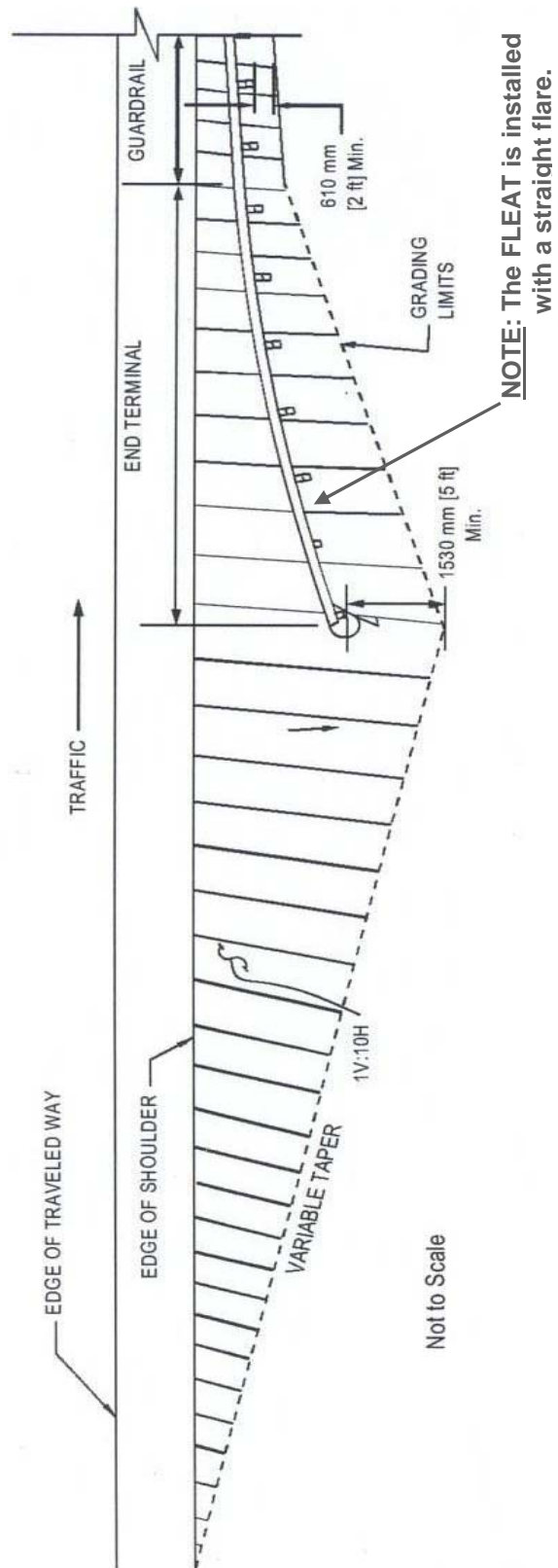

Grading for flared guardrail end treatment

(Reference AASHTO Roadside Design Guide)

Figure 12. Grading Recommendations for **FLEAT-SP**

Installing the SKT-SP & FLEAT-SP

Materials

The pay limit lengths of the **SKT-SP** & **FLEAT-SP** are described under the **General Information** section on pages 2 and 3. The Test Level 2 systems are 25'-0" long. Refer to contract plans.

Site Preparation

When the guardrail is installed parallel to the edge of the shoulder, for the **SKT-SP** a 25:1 (or less) flare away from the roadway is recommended so the impact head will not encroach on the shoulder thereby reducing the potential for nuisance impacts. The flare is not required and may be decreased or eliminated. See **Figure 2**.

The **FLEAT-SP** is installed with a straight flare having an offset anywhere between 2'-6" and 4'-0" over a 37'-6" length. Most times the offset will be 4'-0". Refer to the contract plans for the required offset.

Site grading may be necessary for installations placed beyond the edge of the shoulder to prevent the lower section of the breakaway Steel Posts from extending more than 4" above the ground. See **Figure 11** for the **SKT-SP** and **Figure 12** for the **FLEAT-SP** grading recommendations.

Tools Required

The tools required for installation of the **SKT-SP** & **FLEAT-SP** systems are the same as those used to install standard highway guardrails, including sockets & wrenches, a drill, and other equipment such as augers, tampers, & post pounders commonly used in driving guardrail posts.

Installation Procedures

Begin the installation at the downstream end of the **SKT-SP** or **FLEAT-SP** to ensure that the terminal matches up with the standard downstream section of guardrail. The major steps in the installation of the terminal are as follows:

- Install standard steel guardrail posts #3 and beyond.
- Install breakaway steel end posts #1 and #2.
- Install guardrail. All posts are spaced at 6'-3".
- Install cable anchor bracket.
- Install the **SKT-SP** or **FLEAT-SP** impact head.
- Install cable assembly.

Installing Standard Steel Guardrail Posts #3 and Beyond

All posts at locations #3 and beyond are W6x9# x 6'-0" long standard steel guardrail posts. All posts are spaced at 6'-3" centers. The finished guardrail height should be approximately 27 ¾" above the edge of the shoulder or the finished grade. A height of up to 30" is allowable.

For the **SKT-SP**, if the pay limit for the system is 50'-0" long, posts #3 - #8 will be standard steel guardrail posts. See **Figure 1**.

For the **FLEAT-SP**, if the pay limit for the system is 37'-6" long, posts #3 - #7 will be standard steel guardrail posts. See **Figure 3**.

The acceptable pay limit lengths of the **SKT-SP** & **FLEAT-SP** are described under the **General Information** section on pages 2 and 3.

Installing Breakaway Steel End Posts #1 and #2

Steel posts #1 & #2 are hinged steel posts. These bolted posts must have the lower section installed before attaching the top section. The lower section of the bolted hinged steel posts should not be driven with the upper post attached. *Note that a ground line strut is not required.* Since there is no ground line strut, be sure posts #1 and #2 are spaced at 6'-3" centers.

Upper and lower Post #2 are W6x9# sections. Bolt upper and lower post #2 together with a ¾" x 8 ½" hex bolt and nut. Since a ground strut is not used with the **SKT-SP** or **FLEAT-SP**, an 8" hex bolt will also work. Be sure when the lower segment of the post is installed, the hinge bolt is on the downstream side of the post (opposite the impact head). The upper post #2 has an open-ended slot for the post bolt. Be sure this slot is on the upstream side of the post (toward the impact head). See **Figure 7** for both the **SKT-SP** & **FLEAT-SP** post #2.

Upper Post #1 is a 6" x 6" x ⅛" tube section. Lower Post #1 is a W6x15# post with a soil plate welded to the post. Bolt upper and lower post #1 together with a ⅝" x 9" hex bolt, nut and (2) washers. Be sure when the post is installed, the hinge bolt is on the upstream side of the post (toward the impact head). Be sure when the lower segment of the post is installed, the soil plate is on the downstream side of the post (opposite the impact head). For the **SKT-SP** post #1 see **Figures 4 & 6**. For the **FLEAT-SP** post #1 see **Figures 5 & 6**.

The top of the lower post #1 & #2 stubs should not project more than 4" above the ground line when measured along a 5' cord, in compliance with AASHTO specifications. Site grading may be required if the top of the lower post section project more than 4" above the ground line.

For stiff soils, drill a pilot hole and force the post to the proper depth by impact or vibratory means with an appropriate driving head. Be careful not to drive on the side plates of the lower posts as they may be damaged.

The post may also be installed by augering and backfilling if the contractor so prefers. The initial hole must be large enough to allow adequate room for proper compaction of the soil during backfill. ***Care must be taken to carefully compact the backfill to prevent settlement or lateral displacement of the post.*** If rock is encountered during driving or excavation, refer to appropriate State specifications for how to proceed. Guidelines will vary from State to State.

Installing Guardrail

Attach the standard W-beam guardrail sections (12'-6" or 25'-0" long) downstream of post #3. Attach the **SKT-SP** or **FLEAT-SP** W-beam guardrail end section to span from post 1 to 3 for a 12'-6" long rail, or from post 1 to 5 for a 25'-0" long rail. Most times a universal end panel with 6'-3" post spacing would be supplied. The *universal end panel* can be identified with eight (8) holes $\frac{3}{4}$ " diameter to attach the cable anchor bracket and thirteen (13) slots. Ten (10) slots $\frac{1}{2}$ " x 4" are in the corrugations of the rail and three (3) slots $\frac{1}{2}$ " x 4" are in the valley of the rail.



The **SKT-SP** may use an end panel with only three (3) slots $\frac{1}{2}$ " x 4" in the valley of the rail. The **FLEAT-SP** may use an end panel with only ten (10) slots $\frac{1}{2}$ " x 4" in the corrugations of the rail. The other W-Beam railing sections in the **SKT-SP** or **FLEAT-SP** shall be the same used in highway guardrail with 6'-3" post spacing.

The required offset for the **FLEAT-SP** is achieved by first splicing the guardrail panels together then manually pushing the rails back. Shop curving or bending is not required. All rails are spliced with $\frac{5}{8}$ " x $1\frac{1}{4}$ " H.G.R. (Highway GuardRail) bolts and $\frac{5}{8}$ " H.G.R. nuts.

The **SKT-SP** & **FLEAT-SP** rails are to be attached to posts and blockouts at post locations #3 and beyond with $\frac{5}{8}$ " x 10" H.G.R. bolts and nuts. There is no blockout used on posts 1 and 2. The end rail for the **SKT-SP** & **FLEAT-SP** is attached to post #2 with a $\frac{5}{8}$ " x $1\frac{1}{4}$ " H.G.R. bolt and nut. A post bolt is never used at post #1 for the **SKT-SP** & **FLEAT-SP**.

NOTE: The **FLEAT-SP** rail is not bolted to post #3.

It is recommended that the post bolt for the **SKT-SP** be placed through the rail at post location #5 where the rail splice occurs as that's how the system was crash tested. However, the system will still function properly if post bolt #5 is not attached to the rail.

NOTE: All of the W-Beam railing within the **SKT-SP** & **FLEAT-SP** terminal must be straight. Curving the rail within the terminal is not permitted.

Installing Cable Anchor Bracket

The eight $\frac{1}{2}$ " cable anchor bracket shoulder bolts are attached to the W-beam guardrail end section with two 1-1/16" OD x 9/16" ID structural washers, one on each side of the guardrail, and a $\frac{1}{2}$ " structural nut. Be sure the shoulder bolts are placed with the shoulders of the bolts installed on the backside of the guardrail, away from traffic, as shown in **Figure 8**.

For ease of installation, attach the cable anchor bracket shoulder bolts to the rail "finger tight" only. Then align the slots on the cable anchor bracket with the shoulder bolts and tap the cable anchor bracket onto the shoulder portion of the bolts using a hammer. Tighten the bolts with a wrench when the bracket is in place. The welded plate on the cable anchor bracket should be toward Post #2, as shown in **Figure 9**. Be sure the bracket is fully seated on the shoulder portion of the bolts.

Installing the SKT-SP or FLEAT-SP Impact Head

The eight cable anchor bracket shoulder bolts and the cable anchor bracket should be attached to the W-beam guardrail end section prior to attaching the **SKT-SP** or **FLEAT-SP** impact head to the first post. Note the **FLEAT-SP** impact head will be installed with the rail exit slot on the traffic side.

Place the impact head with the feeder guide chute over the end of the W-beam guardrail. The impact head should be positioned so that the protruding tube is on the backside of the guardrail, away from traffic as shown in **Figures 5 & 6**. Slide the impact head forward until the post angle attachments on the impact head are aligned with the holes in post #1 (6" x 6" x 1/8" tube) as shown in **Figure 10**. Attach the impact head to the first post with two 5/16" x 1" hex bolts, nut and (2) washers, one each for the top and bottom post angle attachments.

NOTE: It is recommended that the face of the impact head be delineated with an object marker that meets State specifications for better night visibility. However, the impact face object marker may not be included as part of the shipped materials for the terminal unless specifically requested in the contract plans.

Installing Cable Assembly

Place the cable assembly through the cable anchor bracket and through the base of post #1. Note that for the **SKT-SP**, the cable assembly is fed inside through the feeder chute of the impact head. For the **FLEAT-SP** be sure the cable assembly is NOT fed through the feeder chute of the impact head.



The **SKT-SP** cable is fed inside through the feeder chute.
The SKT feeder chute is longer than the FLEAT



The **FLEAT-SP** cable NOT
to be fed inside the feeder chute

Place the bearing plate at the base of post 1 with the 5" dimension up and 3" dimension down. See **Figure 6**. Secure the bearing plate with a retainer/tie to prevent the plate from rotating. Secure both ends of the cable assembly with a 1" hex nut and washer. While tightening the cable, use a hammer to tap the cable anchor bracket from the downstream end to ensure that it is securely interlocked with the shoulder bolts. Restrain the cable at the end being tightened with vice grips or channel lock pliers to avoid twisting the cable.

Upon completion of the installation, the cable should be taut and the cable anchor bracket should be fully seated on the shoulder portion of the cable anchor bolts.

NOTE: It is very important that the cable anchor bracket be fully seated on the shoulder portion of the cable anchor bolts as shown in **Figure 9**.

SKT-SP & FLEAT-SP Inspection Checklist

State: _____

Date: _____

Project #: _____

Location: _____

- The rail height is in accordance with the contract plans. This is approximately 27 ¾" above the edge of the finished grade. A height of up to 30" is allowable.
- There is no curved rail within the terminal SKT-SP 50'-0" or FLEAT-SP 37'-6" (TL-3).
- The end rail section is not attached to the post at post location #1.
- The **FLEAT-SP** rail is not attached to the post at post location #3.
- The end rail panel has special slots and all rails are lapped in the proper direction.
- The ¾" x 8 ½" hinge bolt at post #2 is on the downstream side of the post.
- The ⅝" x 9" hinge bolt at post location #1 is on the upstream side of the post.
- The lower stub at posts #1 and #2 do not protrude more than 4" above the ground line (measured by the AASHTO 5' cord method). Site grading may be necessary to meet this requirement.
- At post #2, the open-ended slot at the post bolt is on the upstream side of the post.
- Standard steel W6x9# x 6'-0" guardrail posts are used at post locations #3 and beyond.
- All posts within the **SKT-SP** or **FLEAT-SP** are spaced at 6'-3" centers.
- The **SKT-SP** impact head does not encroach on the shoulder (a maximum 25:1 taper is permitted to eliminate the potential for encroachment).
- The **FLEAT-SP** is installed with a straight flare (offset between 2'-6" & 4'-0") over a 37'-6" terminal length.
- The two 5/16" x 1" hex bolts holding the impact head to post #1 are secured.
- The 8" x 8" bearing plate at post #1 is correctly positioned with the 5" dimension up and the 3" dimension down. The anchor cable is taut and correctly installed. A retainer/tie has been placed over the bearing plate to prevent rotation.
- The cable anchor bracket shoulder bolts are properly attached to the W-beam guardrail and the cable anchor bracket is fully seated on the shoulder portion of the bolts.
- If the posts were augered, the backfill material around the posts is properly compacted.
- No washers are used on the face of the rail except at the cable anchor bracket bolts.
- The finished installation is in accordance with all specific State DOT guidelines.

Additional notes:

Inspection performed by: _____

Repairing the SKT-SP & FLEAT-SP

Equipment Needed for Repair Operation

- Acetylene torch to cut off the damaged rail,
- Heavy duty chain to remove the impact head is sometimes required,
- Tools used to install standard highway guardrails, including sockets & wrenches, etc.,
- Vice grip or channel lock pliers,
- Sledge hammer,

Be sure proper traffic control is deployed to protect workers and motorists. Follow the requirements shown in the *Manual on Uniform Traffic Control Devices* (MUTCD).

General Repair Procedures

After an end-on impact occurs with the **SKT-SP** or **FLEAT-SP**, it will normally require replacement of the first 12'-6" or 25'-0" end section of rail and any other damaged rail section(s) and any broken post(s). For a traffic face impact downstream of the impact head, the damage will typically be to the downstream rail section(s) and associated posts.

The general step-by-step procedure for repairing a damaged terminal is as follows:

- (1) Check the impact head for damage.
- (2) Check the cable assembly for damage. The cable anchor bracket, bearing plate, nuts, washers, cable anchor bracket, and the special cable anchor bracket shoulder bolts are rarely damaged.
- (3) Check the number of broken posts and blockouts that need to be replaced, along with any damaged bolts. Inventory and pick up the reusable parts.
- (4) Torch off the kinked rail at the exit opening near the outlet of the impact head. The impact head may be able to be removed by hand at this point. If not, then hook up a chain attachment through the opening behind the impact plate of the impact head. Pull the impact head off the rail with the chain attached to a truck frame with the W-beam guardrail still attached to the downstream guardrail posts.
- (5) Disconnect and remove the damaged rail from the posts.
- (6) Remove the damaged posts. Hinged posts #1 and #2 can be unbolted. Remove the standard steel "SP" standard guardrail posts.
- (7) Reinstall the system following the procedures listed in this manual.

