

PLAN

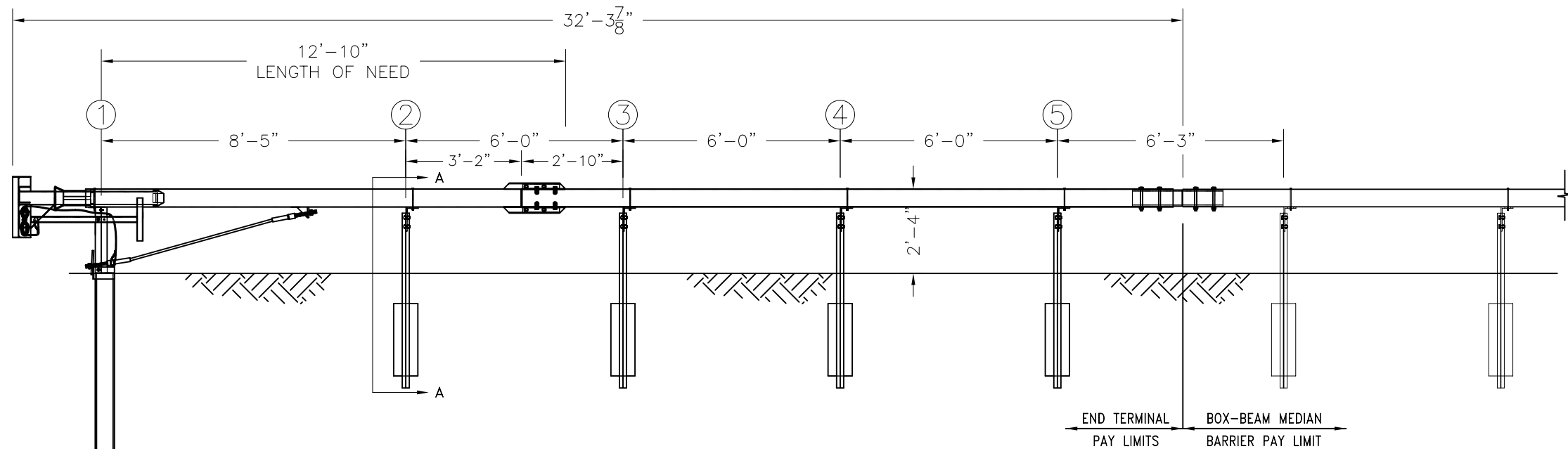

ELEVATION

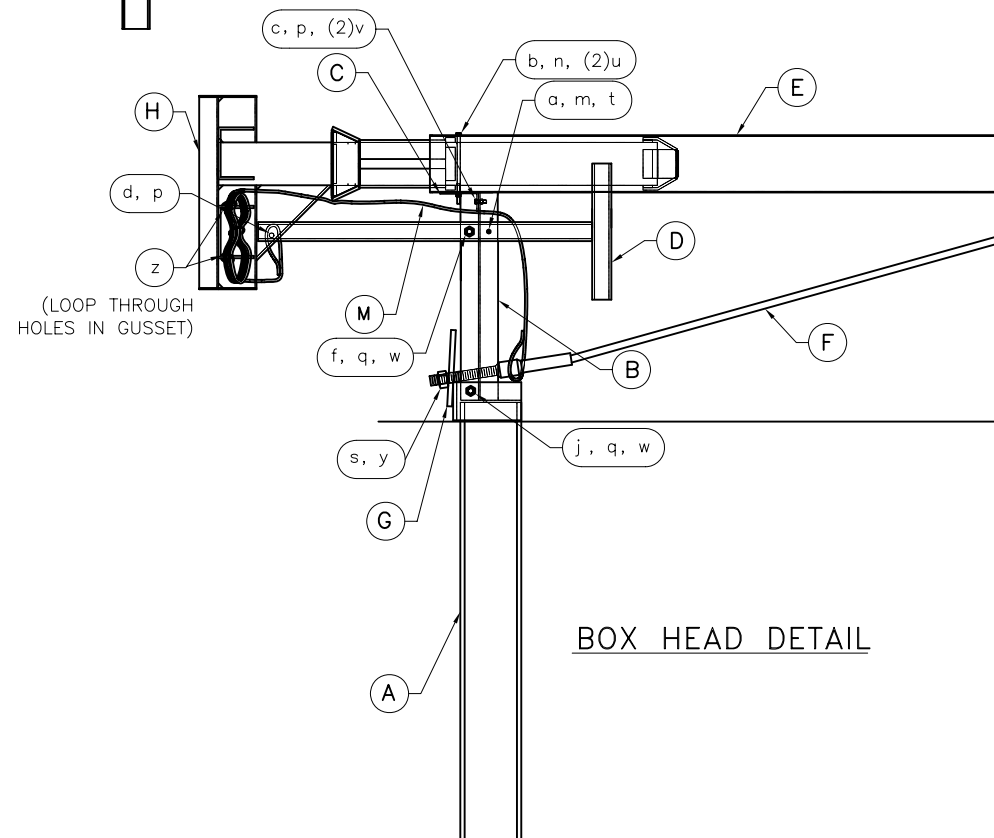

BOX HEAD DETAIL

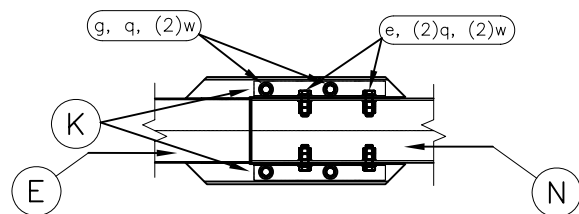

END SPLICE CHANNEL DETAIL

ITEM K SPLICE CHANNELS WILL SET ON THE TOP AND BOTTOM OF ITEM N SECOND RAIL. THE BENT PLATES WELDED TO THE END OF ITEM E END TUBE RAIL WILL SET ON TOP OF ITEM K SPLICE CHANNELS

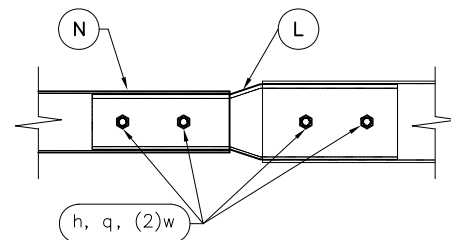

CONNECTION SLEEVE DETAIL

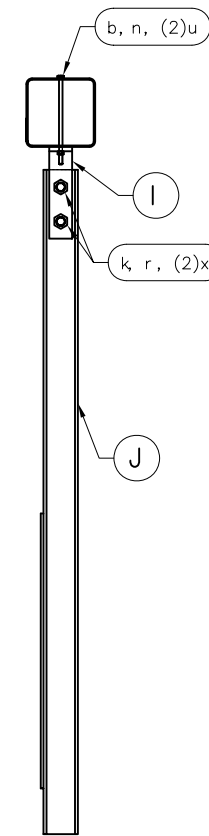

SECTION "A-A"

ITEM	QTY	DESCRIPTION
A	1	LOWER FIRST POST W6x15 x 8'-0" LG.
B	1	UPPER FIRST POST W6x9 1'-9 1/2" LG.
C	1	SUPPORT BRACKET 10 GAGE BENT PLATE
D	1	POST BREAKER
E	1	END TUBE RAIL TS6x6x1/8 x 12'-0" LG.
F	1	CABLE ASSEMBLY
G	1	BEARING PLATE-5/8" X 8" X 8"
H	1	BOX BEAM HEAD
I	4	MEDIAN BARRIER SUPPORT BRACKET
J	4	WEAK BOX BEAM POST w/ SOIL PLATE
K	2	END TUBE SPLICE CHANNEL-DETAIL BELOW
L	1	TS6x6 to 6x8 CONNECTION SLEEVE
M	1	3/8" GALV. CABLE x 20'-0"
N	1	2nd RAIL TS6x6x3/16 x 18'-0" LG.
HARDWARE		
a	1	1/4 x 3" LG. GRADE 2 BOLT
b	5	5/16 x 7 1/2" LG. GRADE 5 BOLT
c	1	1/2 x 2" LG. GRADE 2 BOLT
d	1	1/2 x 5" LG. GRADE 5 BOLT
e	4	5/8 x 2" LG. GRADE 5 BOLT
f	1	5/8 x 3" LG. GRADE 5 BOLT
g	4	5/8 x 6" LG. GRADE 5 BOLT
h	4	5/8 x 7" LG. GRADE 5 BOLT
j	1	5/8 x 8" LG. GRADE 5 BOLT
k	8	3/4 x 1 1/2" LG. GRADE 2 BOLT
m	1	1/4" HEX NUT
n	5	5/16" HEX NUT
p	2	1/2" HEX NUT
q	18	5/8" HEX NUT
r	8	3/4" HEX NUT
s	2	1" ANCHOR CABLE HEX NUT
t	1	1/4" WASHER
u	10	5/16" WASHER
v	2	1/2" WASHER
w	26	5/8" WASHER
x	16	3/4" WASHER
y	2	1" ANCHOR CABLE WASHER
z	2	CABLE TIE

NOTE:  
TIE 3/8" CABLE USING CABLE TIES ON OPPOSITE SIDE OF THE POST BREAKER

<p>Big Spring, TX Phone: 432-263-2435 or Phone: 330-346-0721</p>	<p><b>BEAT-MT Box-Beam Median Terminal Assembly Drawing Layout &amp; Details</b></p>	Sheet:	<b>A1</b>
		Date:	10/5/2006
Drawing Name:	BEAT-MT-RS	Scale:	NONE
By:	AMC		