

# Installation Instructions for **BEAT**

## Box Beam Bursting Energy Absorbing Terminal



and

## **BEAT-MT** Median Terminal



*R O A D S Y S T E M S , I N C .*

P. O. Box 2163

Big Spring, Texas 79721

Phone: (432) 263-2435 FAX: (432) 267-4039

**Technical Support & Marketing Phone: (330) 346-0721**

**Technical Support & Marketing Fax: (330) 346-0722**

This Installation Manual can be downloaded from RSI web site  
[www.roadsystems.com](http://www.roadsystems.com)



# Table of Contents

	<u>Page</u>
<b><u>Installation Instructions for the BEAT &amp; BEAT-MT</u></b> .....	2
Introduction .....	2
Installation Procedure General Notes.....	2
<b><u>BEAT Roadside Terminal Installation</u></b> .....	3
Isometric View of Roadside BEAT / <b>Figure 1</b> .....	4
Plan and Elevation of Roadside BEAT / <b>Figure 2</b> .....	5
BEAT Roadside Terminal Bill of Materials / <b>Figure 3</b> .....	6
BEAT Roadside Terminal Installation Procedure.....	7
Install the 3” Weak Posts with Soil Plate.....	7
Install Upper & Lower Post #1 Sections.....	7
Install 6”x 6” Box Beam Tubing, Splices, Support Brackets .....	7
Post #1 Connection Details for the Roadside BEAT / <b>Figure 4</b> .....	8
First Rail Tie Plate Section for the Roadside BEAT / <b>Figure 5</b> .....	9
Post #2 Connection Detail for the Roadside BEAT / <b>Figure 6</b> .....	9
Install BEAT Impact Head.....	10
Install Post Breaker .....	10
Install Cable Assembly with Bearing Plate .....	10
<b><u>BEAT-MT Median Terminal Installation</u></b> .....	11
Isometric View of Median BEAT-MT / <b>Figure 7</b> .....	12
Plan and Elevation of Median BEAT-MT / <b>Figure 8</b> .....	13
BEAT-MT Median Terminal Bill of Materials / <b>Figure 9</b> .....	14
BEAT-MT Median Terminal Installation Procedure.....	15
Install the 3” Weak Posts with Soil Plate.....	15
Install Upper & Lower Post #1 Sections.....	15
Install 6”x 6” Box Beam Tubing, Splices, Support Brackets .....	15
Post #1 Connection Details for the Median BEAT-MT / <b>Figure 10</b> .....	16
Connection Sleeve Section for the Median BEAT-MT / <b>Figure 11</b> .....	17
First Rail Tie Plate Section for the Median BEAT-MT / <b>Figure 12</b> .....	17
Posts #2-#5 Connection Detail for the Median BEAT-MT / <b>Figure 13</b> ....	17
Install BEAT-MT Impact Head .....	18
Install Post Breaker .....	18
Install Tether Cable .....	18
Install Cable Assembly with Bearing Plate .....	18
<b><u>Installation Checklist for the BEAT &amp; BEAT-MT</u></b> .....	19
<b><u>Installation Recommendations When Rock is Encountered</u></b> .....	20

# **BEAT & BEAT-MT Box Beam Terminals**

## **INTRODUCTION:**

Note that this Installation Manual is divided into 2 sections:

The first section is for the **roadside BEAT** system for 6"x 6" box beam barrier.

The second section is for the **median BEAT-MT** system for 6"x 8" box beam barrier.

Many of the components of the **BEAT** and **BEAT-MT** are interchangeable. The major difference between the two systems is that the 3" I-beam posts (at post locations #2 and beyond) are mounted behind the box beam rail for the roadside **BEAT** and underneath the rail in the **BEAT-MT**. This means different mounting brackets are required. The front anchor posts for the roadside and median systems are identical. In addition, the median **BEAT-MT** requires a sleeve to connect the 6"x 6" terminal tubing section to the 6"x 8" median barrier tubing, as well as a tether cable to restrain the impact head during reverse direction impacts.

The pay limit length for the **BEAT** and **BEAT-MT** terminals sometimes varies between States. The lengths shown in this manual are for the **BEAT** (~14 feet) and for the **BEAT-MT** (~32 feet). When longer pay limit lengths are shown on the contract plans, additional sections of 6"x 6" box beam rail will be utilized in the roadside **BEAT** and the median **BEAT-MT** systems.

Both of these systems require that an 18'-0" long section of standard 6"x 6" x 3/16" box beam rail must be connected to the 12'-0" long first end rail section. For that reason, the **BEAT-MT** is shipped with the 18'-0" long second rail section, posts, brackets, & hardware as part of the median terminal. In the roadside **BEAT**, the installer must make certain that the (~14 feet long) terminal is attached to (as a minimum) 18'-0" of standard 6"x 6" box beam rail. In both the roadside **BEAT** and median **BEAT-MT**, longer sections of 6"x 6" box beam rail are permissible, but a total length shorter than 30'-0" cannot be utilized within the terminal.

## **INSTALLATION PROCEDURE GENERAL NOTES:**

Begin the installation at the downstream end of the **BEAT / BEAT-MT** to ensure that the terminal matches up with the box beam tubing section it is protecting. The major installation steps for the **BEAT / BEAT-MT** are as follows:

- Install the 3" weak posts with soil plate
- Install upper & lower post #1 sections
- Install 6"x 6" box beam tubing with splices and support brackets  
(Note that the end tube is only 1/8" wall thickness and 12 feet long)
- Install **BEAT** impact head
- Install post breaker (and Tether Cable for **BEAT-MT**)
- Install cable assembly with bearing plate

# BEAT

## Roadside Terminal

### Installation



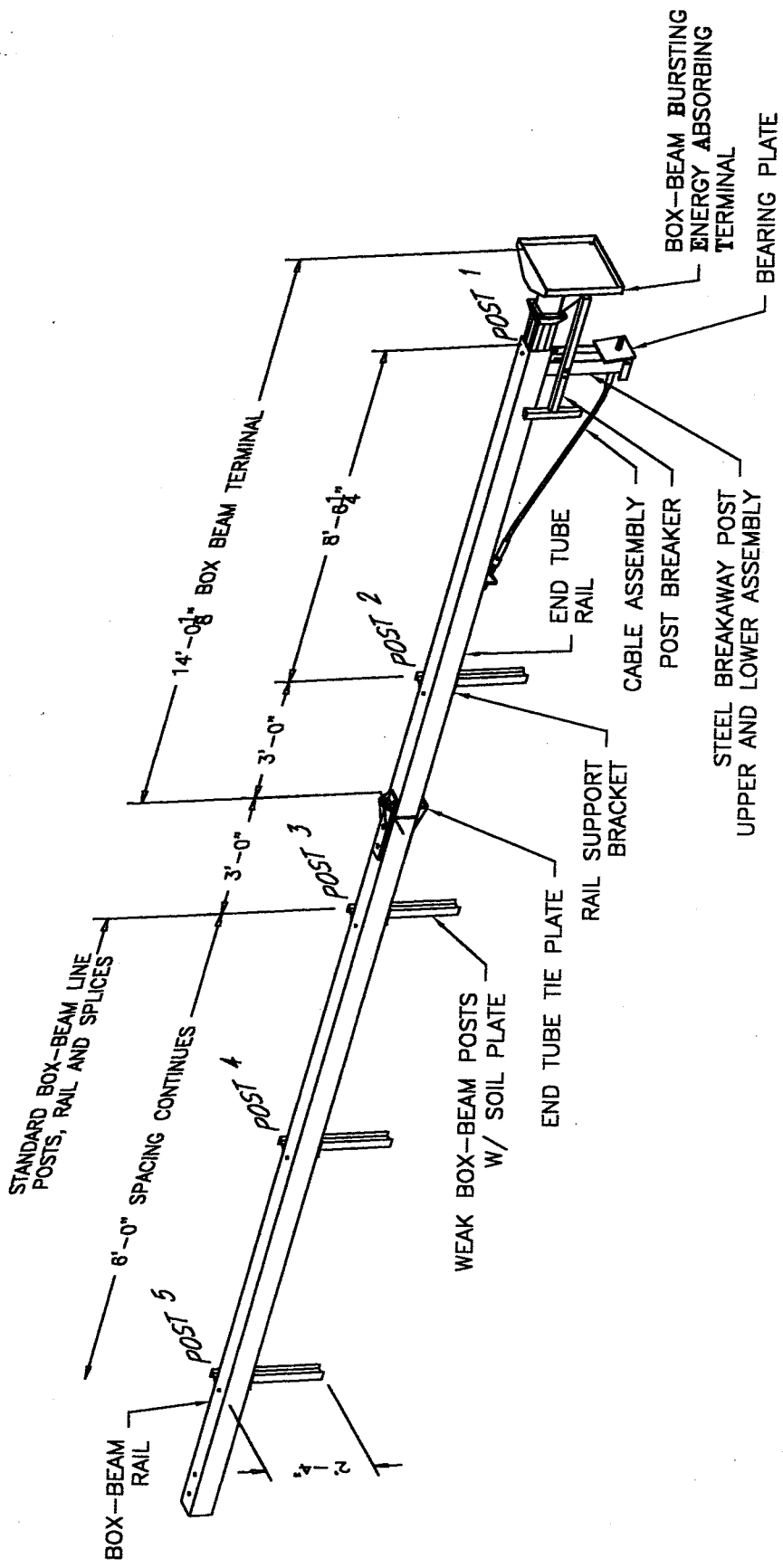

Figure 1. Isometric View of the Roadside BEAT

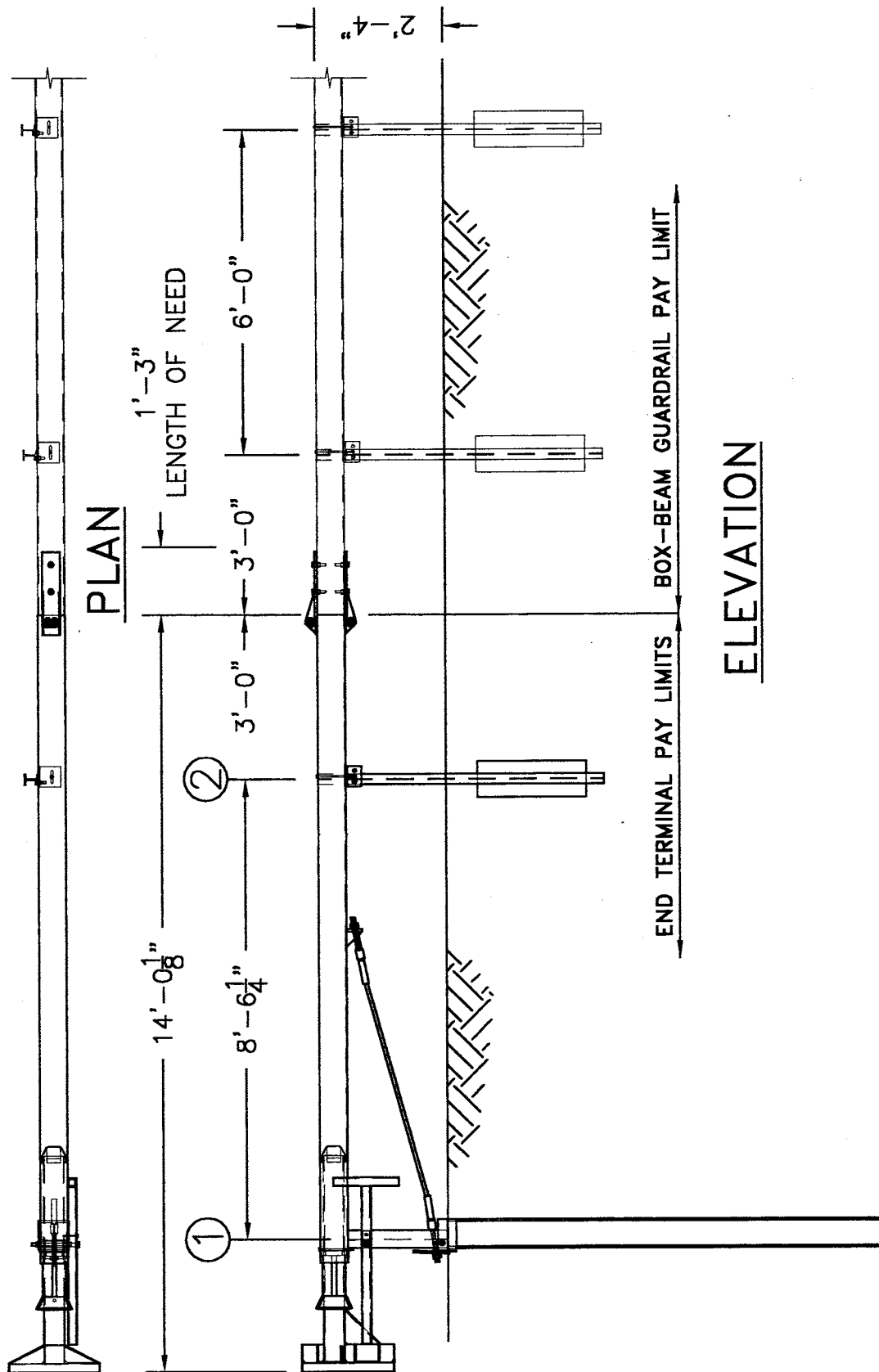

Figure 2. Plan and Elevation of the Roadside BEAT

ITEM	QTY	DESCRIPTION
<b>A</b>	1	LOWER FIRST POST W6x15 x 8'-0" LG.
<b>B</b>	1	UPPER FIRST POST W6x9 1'-9 1/2" LG.
<b>C</b>	1	SUPPORT BRACKET 10 GAGE BENT PLATE
<b>D</b>	1	POST BREAKER
<b>E</b>	1	END TUBE RAIL TS6x6x1/8 x 12'-0" LG.
<b>F</b>	1	CABLE ASSEMBLY
<b>G</b>	1	BEARING PLATE
<b>H</b>	1	BOX BEAM HEAD
<b>I</b>	1	RAIL SUPPORT BRACKET L5x3 1/2x3/8 x 4 1/2" LG.
<b>J</b>	1	WEAK BOX BEAM POST w/ SOIL PLATE
<b>K</b>	2	END TUBE SECTION TIE PLATE
		HARDWARE
<b>a</b>	2	5/16 x 7 1/2" LG. GRADE 5 BOLT
<b>b</b>	1	1/4 x 3" LG. GRADE 2 BOLT
<b>c</b>	2	1/2 x 2" LG. GRADE 2 BOLT
<b>d</b>	8	5/8 x 2" LG. GRADE 5 BOLT
<b>e</b>	1	5/8 x 8" LG. GRADE 5 BOLT
<b>f</b>	1	5/8 x 3" LG. GRADE 5 BOLT
<b>g</b>	2	5/16" HEX NUT
<b>h</b>	1	1/4" HEX NUT
<b>j</b>	2	1/2" HEX NUT
<b>k</b>	14	5/8" HEX NUT
<b>m</b>	2	1" ANCHOR CABLE HEX NUT
<b>n</b>	4	5/16" WASHER
<b>p</b>	1	1/4" WASHER
<b>q</b>	3	1/2" WASHER
<b>r</b>	10	5/8" WASHER
<b>s</b>	2	1" ANCHOR CABLE WASHER

Figure 3. BEAT Roadside Terminal Bill of Material

# **BEAT Roadside Terminal Installation Procedure**

## **Install the 3" Weak Posts with Soil Plate**

Layout a string line and mark off the required post spacing. See **Figure 1** and **Figure 2** for layout. The soil plates are welded to the 3" weak posts and must be positioned the same direction as the rail as shown in **Figure 2**. The posts should be driven with a guardrail post pounder. For stiff soils, drill a pilot hole and force the post to the appropriate depth by impact or vibratory means with a guardrail post pounder. The post may also be installed by augering and backfilling if the contractor so prefers. If augering the hole, the initial hole must be large enough to allow adequate room for proper compaction of the soil during backfill. *Care must be taken to carefully compact the backfill to prevent settlement or lateral displacement of the post.*

## **Install Upper & Lower Post #1 Sections**

The first post is spaced 8'-6 ¼" from post #2 and consists of an upper and lower section. The lower section is a W6x 15# beam 8'-0" long. Be sure the lower post is installed with the ¾" diameter hole on the top of the post located on the front upstream side opposite post #2. It may be driven with a guardrail post pounder. For non-penetrable soil, drill a pilot hole and force the post to the appropriate depth by impact or vibratory means with an approved guardrail post pounder. The post may also be installed by augering and backfilling if the contractor so prefers. If augering the hole, the initial hole must be large enough to allow adequate room for proper compaction of the soil during backfill. *Care must be taken to carefully compact the backfill to prevent settlement or lateral displacement of the post.* See section in the back of this manual for "Installation Recommendations When Rock is Encountered".

Align the ¾" diameter holes in the upper and lower post sections and attach the upper post section to the lower post section using one 5/8"x 8" hex bolt, nut and washer. See **Figure 4**.

## **Install 6"x 6" Box Beam Tubing with Splices & Support Brackets**

At this point all of the standard roadside 6"x 6" box beam barrier and posts should be in place. Attach the 12 foot long 6"x 6" x 1/8" end tube section to the standard 6"x 6" x 3/16" tube section using the first rail tie plate section and 5/8" x 2" hex bolts, nuts and washers. Install the double nutted rail tie plate section to the leading end of the second rail section prior to putting the first rail section into place. See **Figure 5**. This end tube section is a special 1/8" thickness tube as supplied by the manufacturer and has the corners cut at the approach end where the impact head is placed. Note that two nuts are used for each bolt at the tie plate connection to the standard tube section.

Attach the end tube to post #2 using a 5"x 3 ½"x 3/8" rail support bracket and a 5/16"x 7 ½" hex bolt, nut and 2 washers. The rail support bracket is attached to the post #2 with a ½"x 2" hex bolt, nut and washer. See **Figure 6**.

The end tube is also attached to post #1 using a bent plate support bracket. This support bracket is attached to post #1 with a ½"x 2" hex bolt, nut and 2 washers. Do not attach the end tube to the support bracket until the impact head is installed. See **Figure 4**.

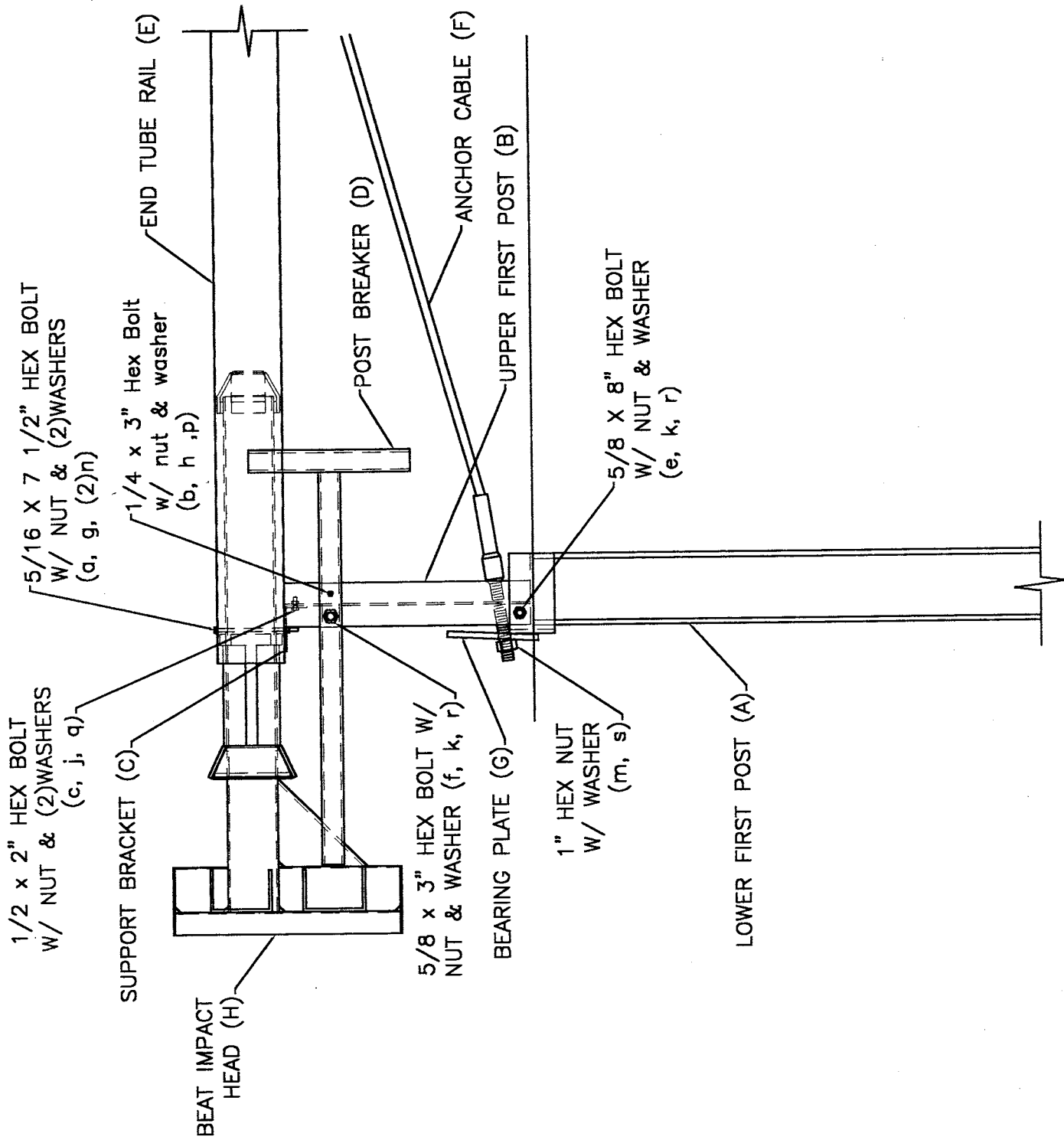

Figure 4. Post #1 Connection Details for the Roadside BEAT

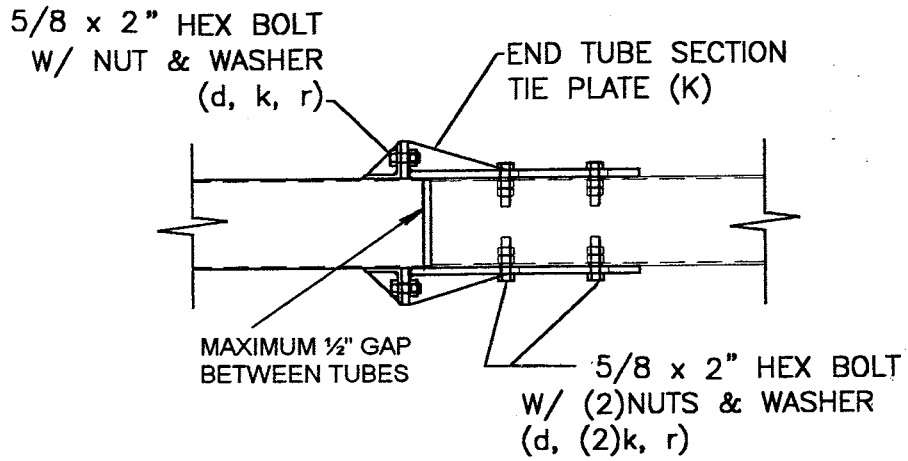

Figure 5. First Rail Tie Plate Section for the Roadside BEAT

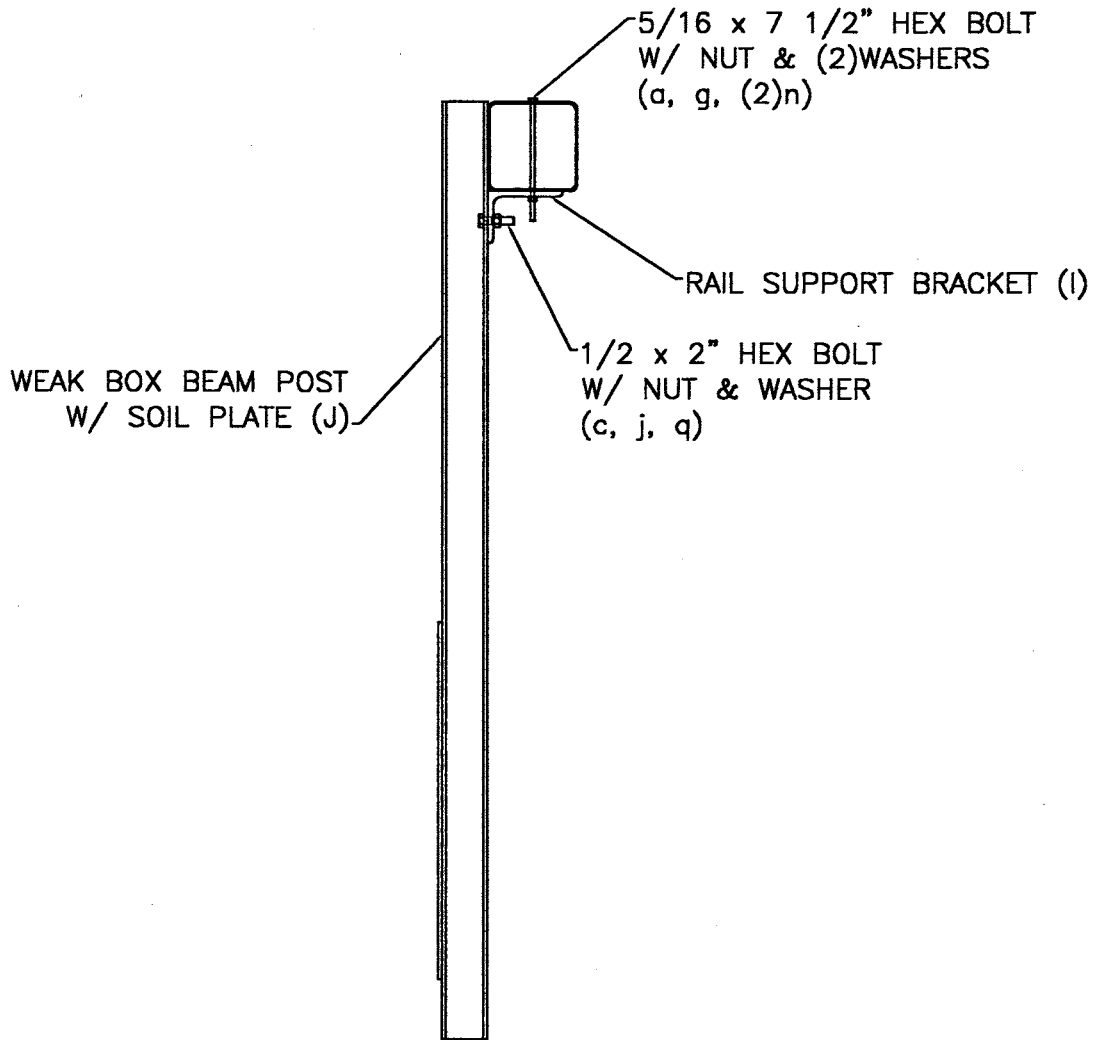

Figure 6. Post #2 Connection Detail for the Roadside BEAT

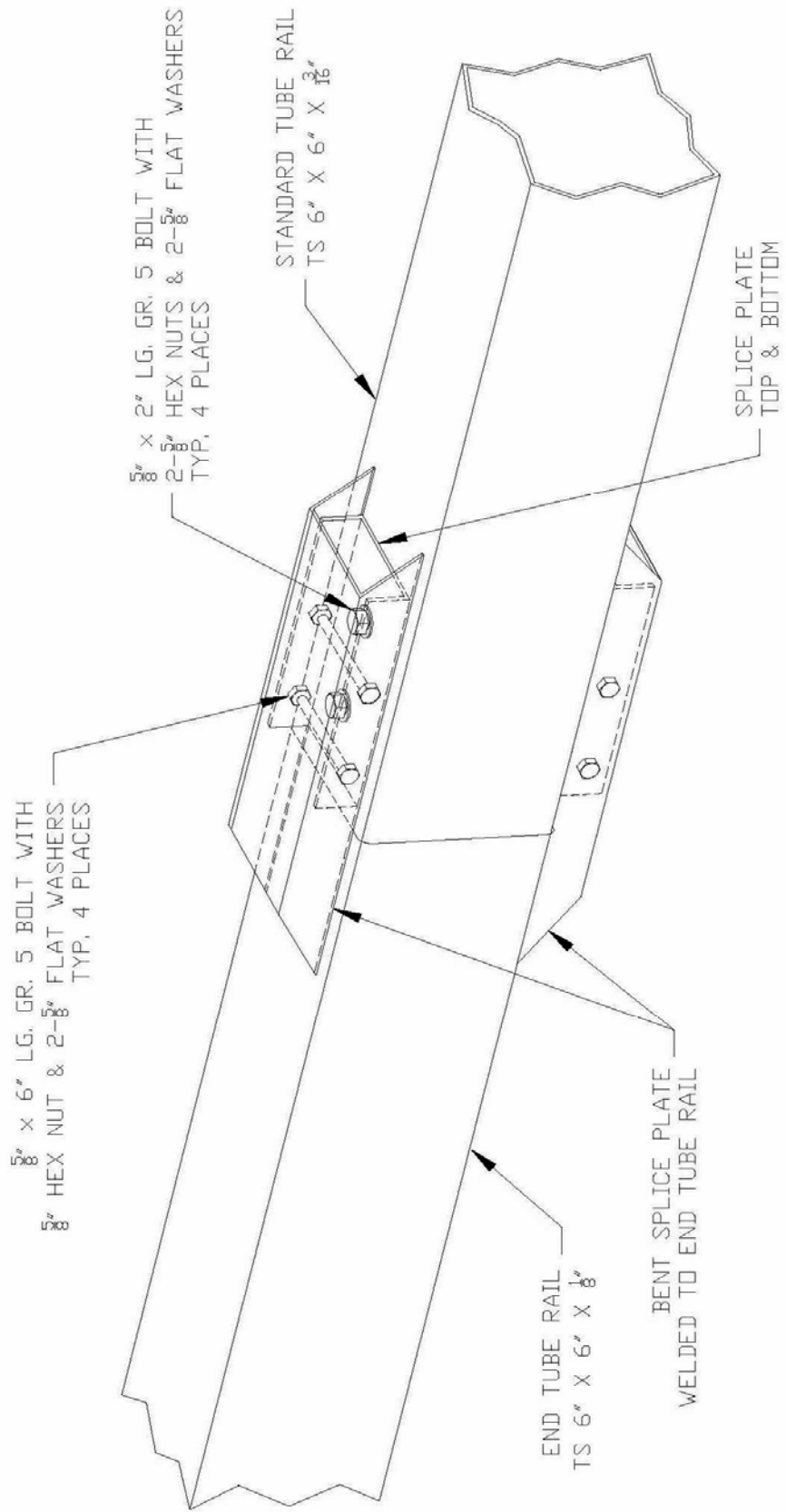

Figure 5a. **Optional** First Rail Tie Plate for the BEAT

## **Install BEAT Impact Head**

Place the impact head inside the end tube. The impact head should be positioned so the holes at the end of the tube and the hole in the impact head are aligned. Also be sure the impact head is inserted into the end tube section with the large triangular gusset plates facing down. Attach the end tube to impact head using a 5/16"x 7 1/2" hex bolt, nut and 2 washers. See **Figure 4**.

Note. It is recommended that the front face of the impact head be delineated with an object marker that meets local specifications for better night visibility. However, the impact face object marker is not included as part of the shipped materials for the BEAT unless specifically requested in the contract plans.

## **Install Post Breaker**

Attach the post breaker to the traffic side of post #1 with a 5/8"x 3" hex bolt, nut and washer and a 1/4"x 3" hex bolt, nut and washer. See **Figure 4**.

## **Install Cable Assembly with Bearing Plate**

Place the cable assembly through the lug welded to the underside of the end tube near post #2 and through post 1. Place the bearing plate at the base of post #1 with the 5" dimension up and the 3" dimension down. Secure both ends of the cable assembly with a 1" hex nut and washer. While tightening the nuts at the end of the cable, restrain the cable at the end being tightened to avoid twisting the cable.

Upon completion of the installation, the cable should be taut.

# **BEAT-MT**

## **Median Terminal**

### **Installation**

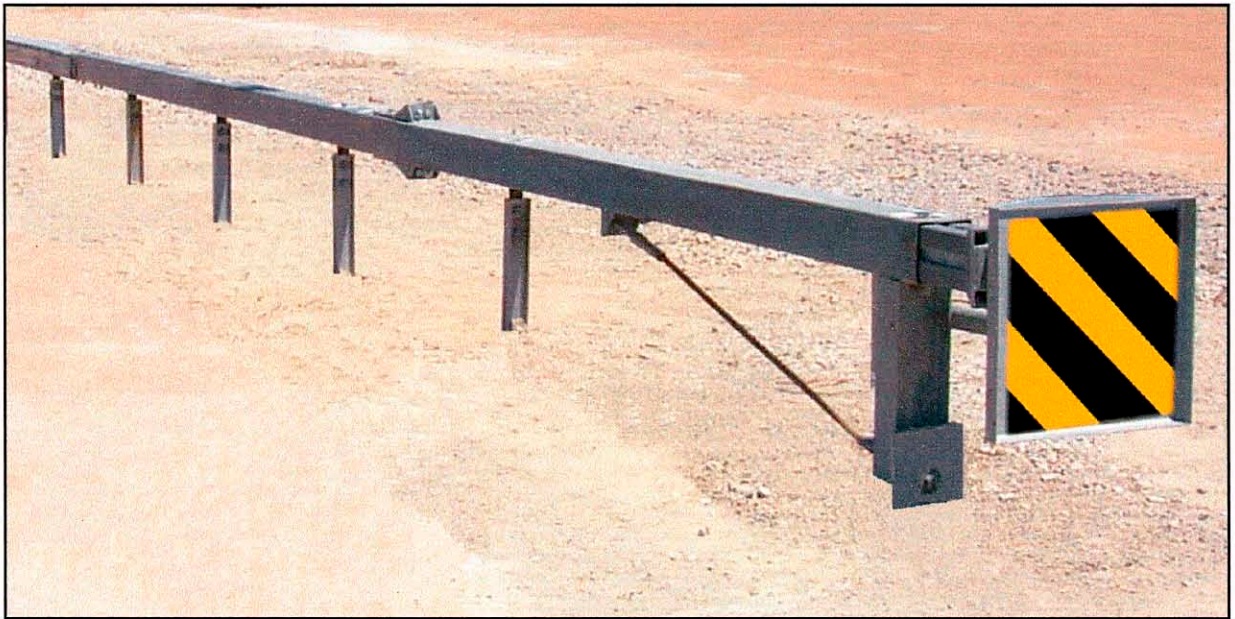

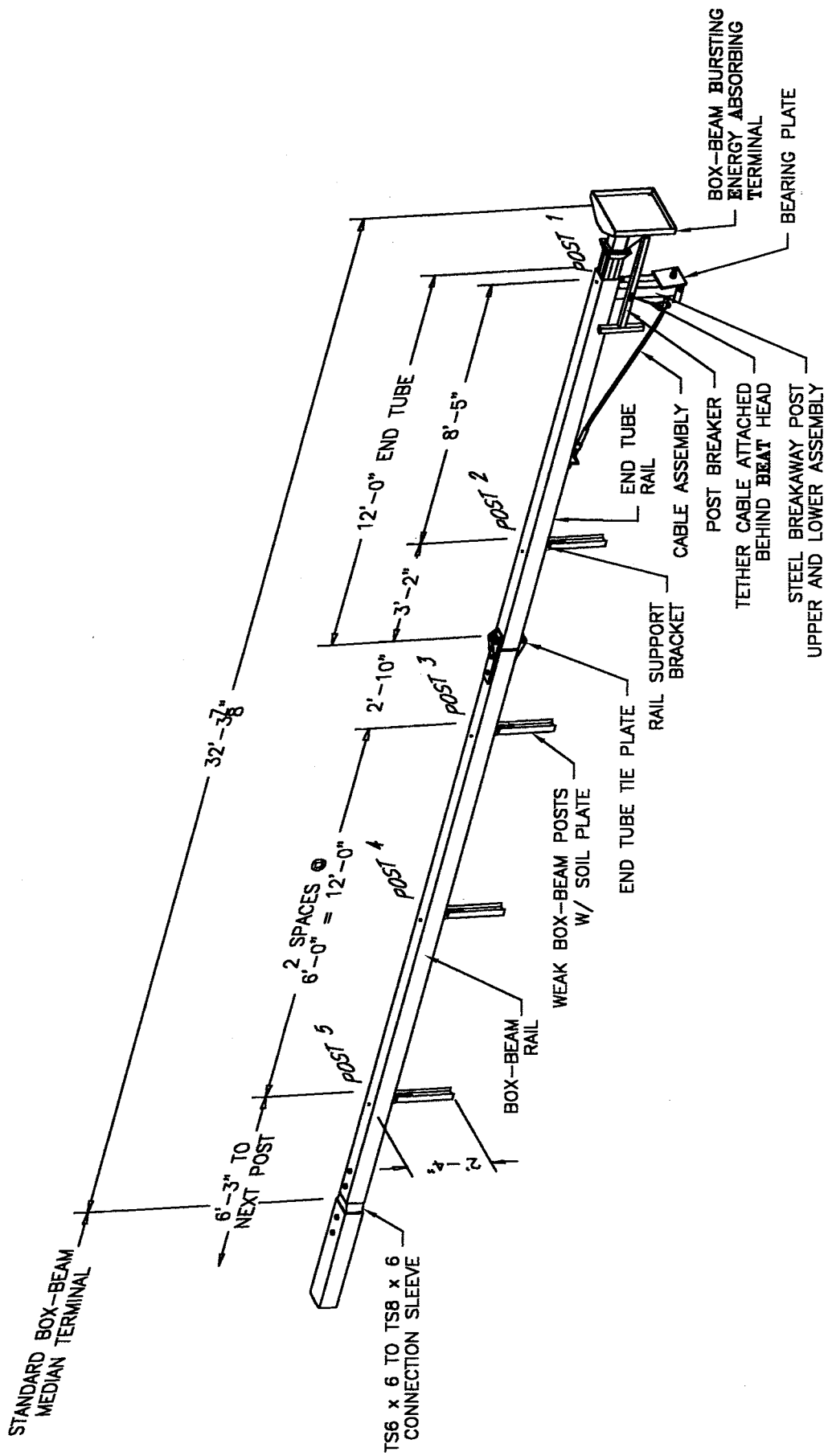

Figure 7. Isometric View of the Median BEAT-MT

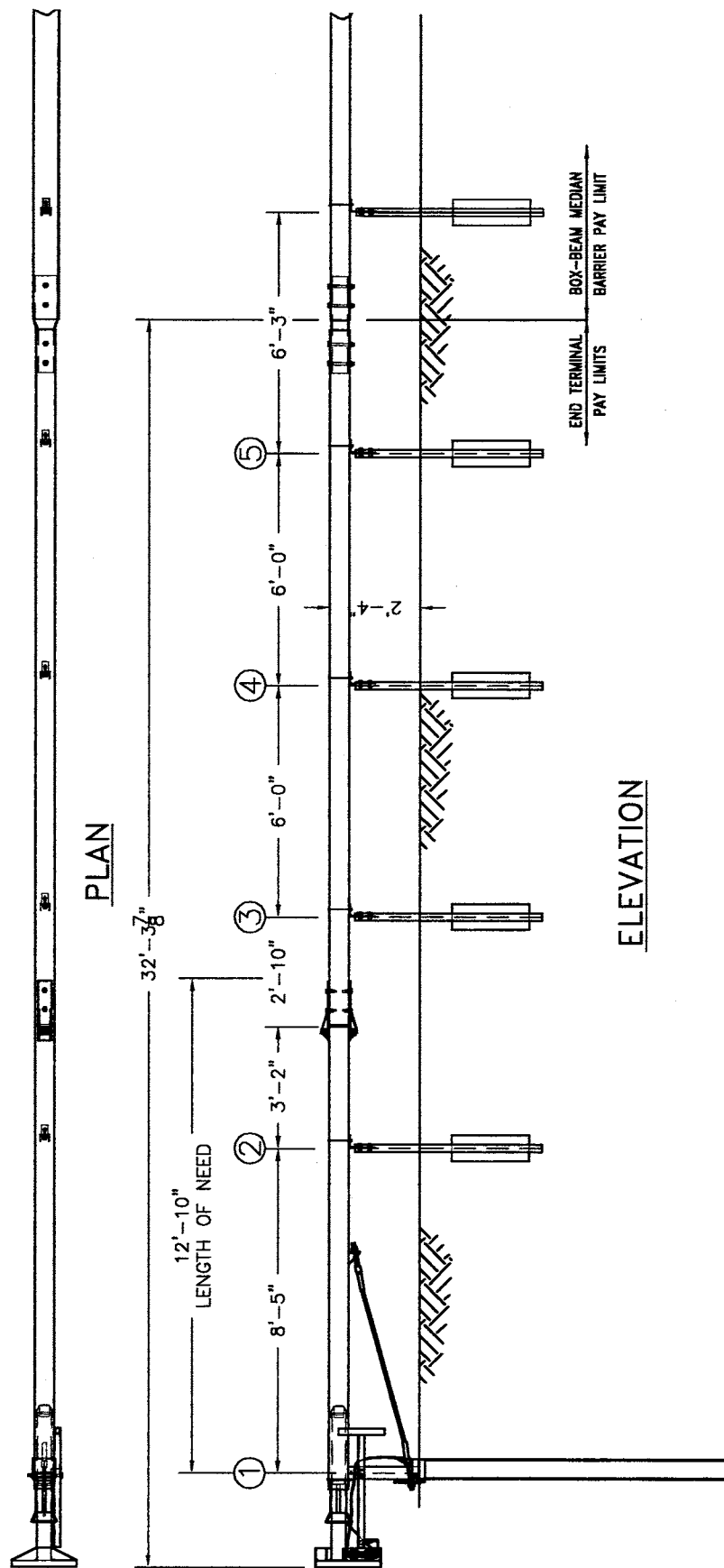

Figure 8. Plan and Elevation of the Median BEAT-MT

ITEM	QTY	DESCRIPTION
A	1	LOWER FIRST POST W6x15 x 8'-0" LG.
B	1	UPPER FIRST POST W6x9 1'-9 1/2" LG.
C	1	SUPPORT BRACKET 10 GAGE BENT PLATE
D	1	POST BREAKER
E	1	END TUBE RAIL TS6x6x1/8 x 12'-0" LG.
F	1	CABLE ASSEMBLY
G	1	BEARING PLATE
H	1	BOX BEAM HEAD
I	4	MEDIAN BARRIER SUPPORT BRACKET
J	4	WEAK BOX BEAM POST w/ SOIL PLATE
K	2	END TUBE SECTION TIE PLATE
L	1	TS6x6 to 6x8 CONNECTION SLEEVE
M	1	3/8" GALV. CABLE x 20'-0"
N	1	2nd RAIL TS6x6x3/16 x 18'-0" LG.
		HARDWARE
a	5	5/16 x 7 1/2" LG. GRADE 5 BOLT
b	1	1/4 x 3" LG. GRADE 2 BOLT
c	1	1/2 x 2" LG. GRADE 2 BOLT
d	1	1/2 x 5" LG. GRADE 5 BOLT
e	8	5/8 x 2" LG. GRADE 5 BOLT
f	1	5/8 x 3" LG. GRADE 5 BOLT
g	4	5/8 x 7" LG. GRADE 5 BOLT
h	1	5/8 x 8" LG. GRADE 5 BOLT
i	8	3/4 x 1 1/2" LG. GRADE 2 BOLT
j	5	5/16" HEX NUT
k	1	1/4" HEX NUT
m	2	1/2" HEX NUT
n	18	5/8" HEX NUT
p	8	3/4" HEX NUT
q	2	1" ANCHOR CABLE HEX NUT
r	10	5/16" WASHER
s	1	1/4" WASHER
t	2	1/2" WASHER
u	18	5/8" WASHER
v	16	3/4" WASHER
w	2	1" ANCHOR CABLE WASHER
x	2	CABLE TIE

Figure 9. BEAT-MT Median Terminal Bill of Material

# **BEAT-MT Median Terminal Installation Procedure**

## **Install the 3" Weak Posts with Soil Plate**

Layout a string line and mark off the required post spacing. See **Figure 7** and **Figure 8** for layout. The soil plates are welded to the 3" weak posts and must be positioned the same direction as the rail as shown in **Figure 8**. The posts should be driven with a guardrail post pounder. For stiff soils, drill a pilot hole and force the post to the appropriate depth by impact or vibratory means with a guardrail post pounder. The post may also be installed by augering and backfilling if the contractor so prefers. If augering the hole, the initial hole must be large enough to allow adequate room for proper compaction of the soil during backfill. *Care must be taken to carefully compact the backfill to prevent settlement or lateral displacement of the post.*

## **Install Upper & Lower Post #1 Sections (Same as used in roadside BEAT)**

The first post is spaced 8'-5" from post #2 and consists of an upper and lower section. The lower section is a W6x 15# beam 8'-0" long. Be sure the lower post is installed with the ¾" diameter hole on the top of the post located on the front upstream side opposite post #2. It may be driven with a guardrail post pounder. For non-penetrable soil, drill a pilot hole and force the post to the appropriate depth by impact or vibratory means with an approved guardrail post pounder. The post may also be installed by augering and backfilling if the contractor so prefers. If augering the hole, the initial hole must be large enough to allow adequate room for proper compaction of the soil during backfill. *Care must be taken to carefully compact the backfill to prevent settlement or lateral displacement of the post.* See section in the back of this manual for "Installation Recommendations When Rock is Encountered".

Align the ¾" diameter holes in the upper and lower post sections and attach the upper post section to the lower post section using one 5/8"x 8" hex bolt, nut and washer. See **Figure 10**.

## **Install 6"x 6" Box Beam Tubing with Splices & Support Brackets**

At this point all of the standard median 6"x 8" box beam barrier and posts should be in place. First, attach the 6"x 6" x 3/16" x 18 foot long standard tube section to the 6"x 8" median barrier using the connection sleeve and 5/8"x 7" hex bolts, nuts and 2 washers. See **Figure 11**. Next, attach the 12 foot long 6"x 6" x 1/8" end tube section to the standard 6"x 6" x 3/16" tube section using the first rail tie plate section and 5/8"x 2" hex bolts, nuts and washers. Install the double nutted rail tie plate section to the leading end of the second rail section prior to putting the first rail section into place. See **Figure 12**. This end tube section is a special 1/8" thickness tube as supplied by the manufacturer and has the corners cut at the approach end where the impact head is placed. Note that two nuts are used for each bolt at the tie plate connection to the standard tube section.

Attach the end tube and 18'-0" long standard tube sections to posts #2 through #5 using a median barrier support bracket and a 5/16"x 7 ½" hex bolt, nut and 2 washers. The support brackets are attached to the posts with two ¾"x 1 ½" hex bolts, nuts and washers. See **Figure 13**.

The end tube is also attached to post #1 using a bent plate support bracket. This support bracket is attached to post #1 with a ½"x 2" hex bolt, nut and 2 washers. Do not attach the end tube to the support bracket until the impact head is installed as there will be interference. See **Figure 10**.

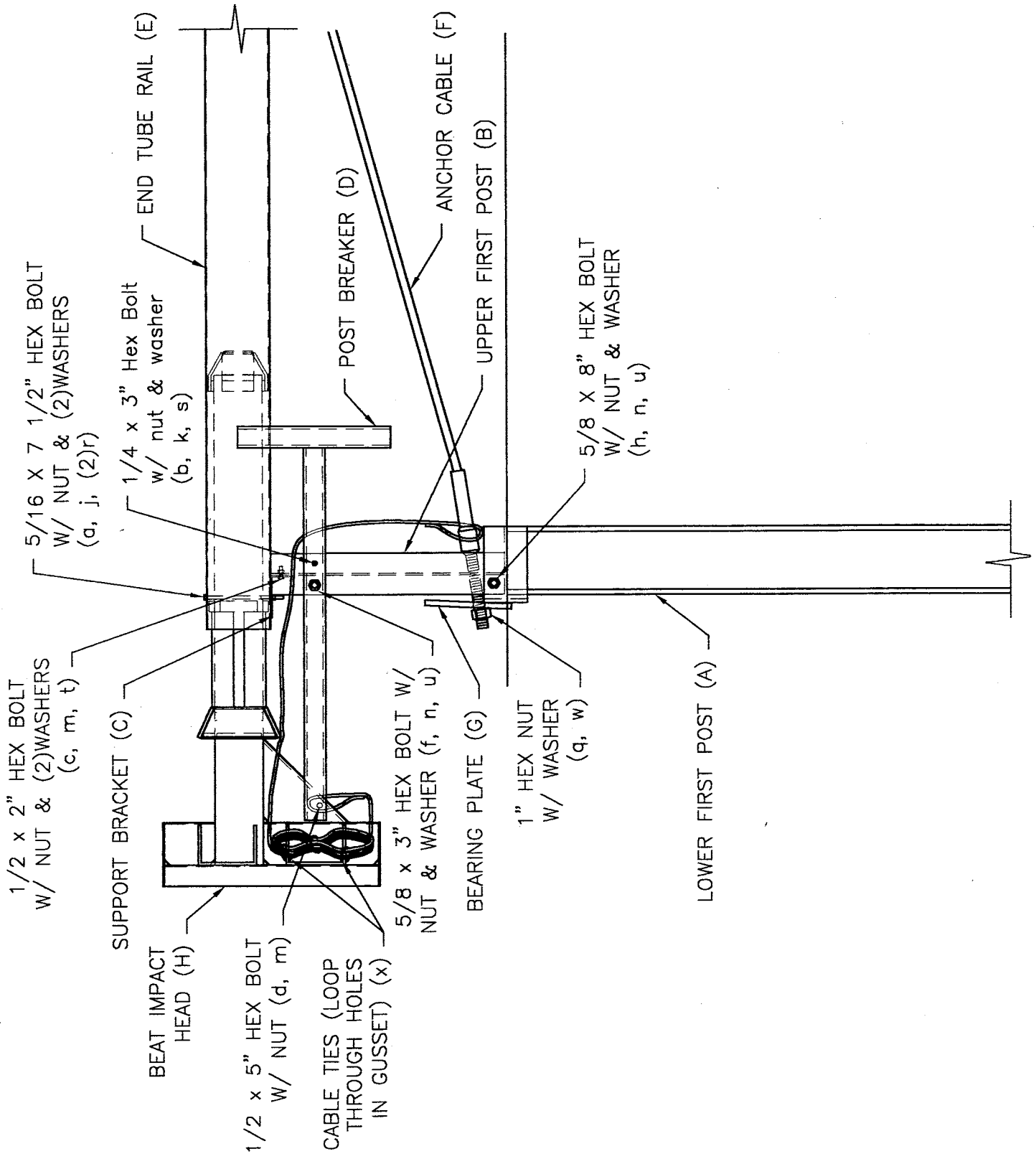

Figure 10. Post #1 Connection Details for the Median BEAT-MT

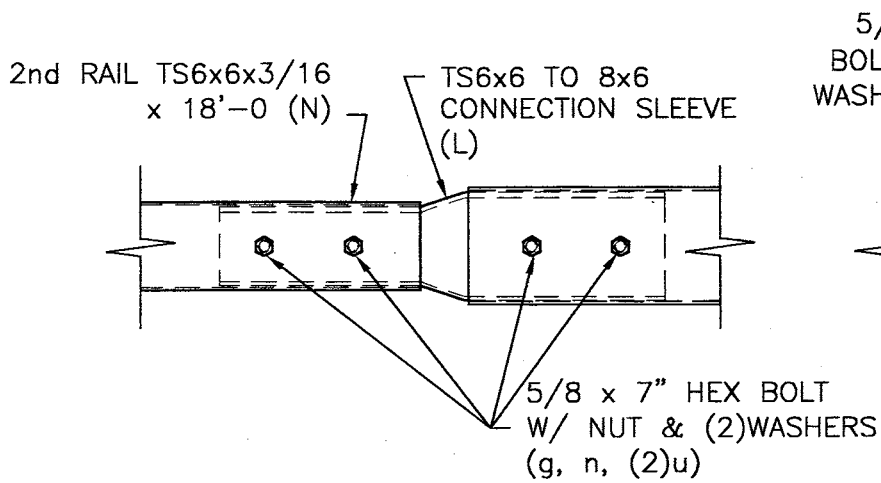

Figure 11. Connection Sleeve Section for the Median BEAT-MT

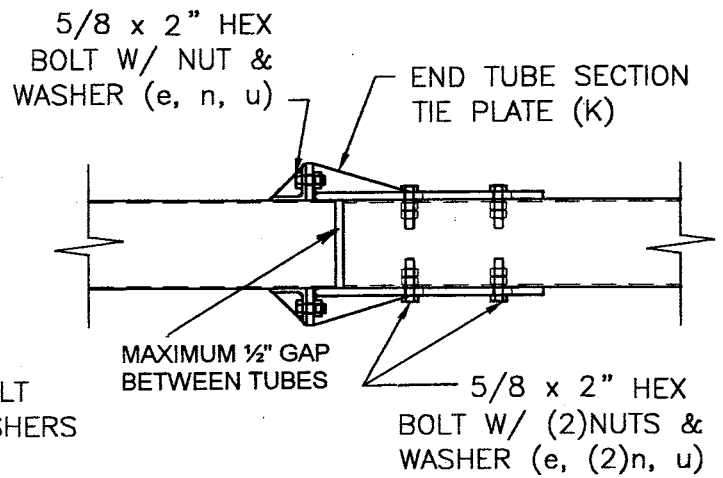

Figure 12. First Rail Tie Plate Section for the Median BEAT-MT

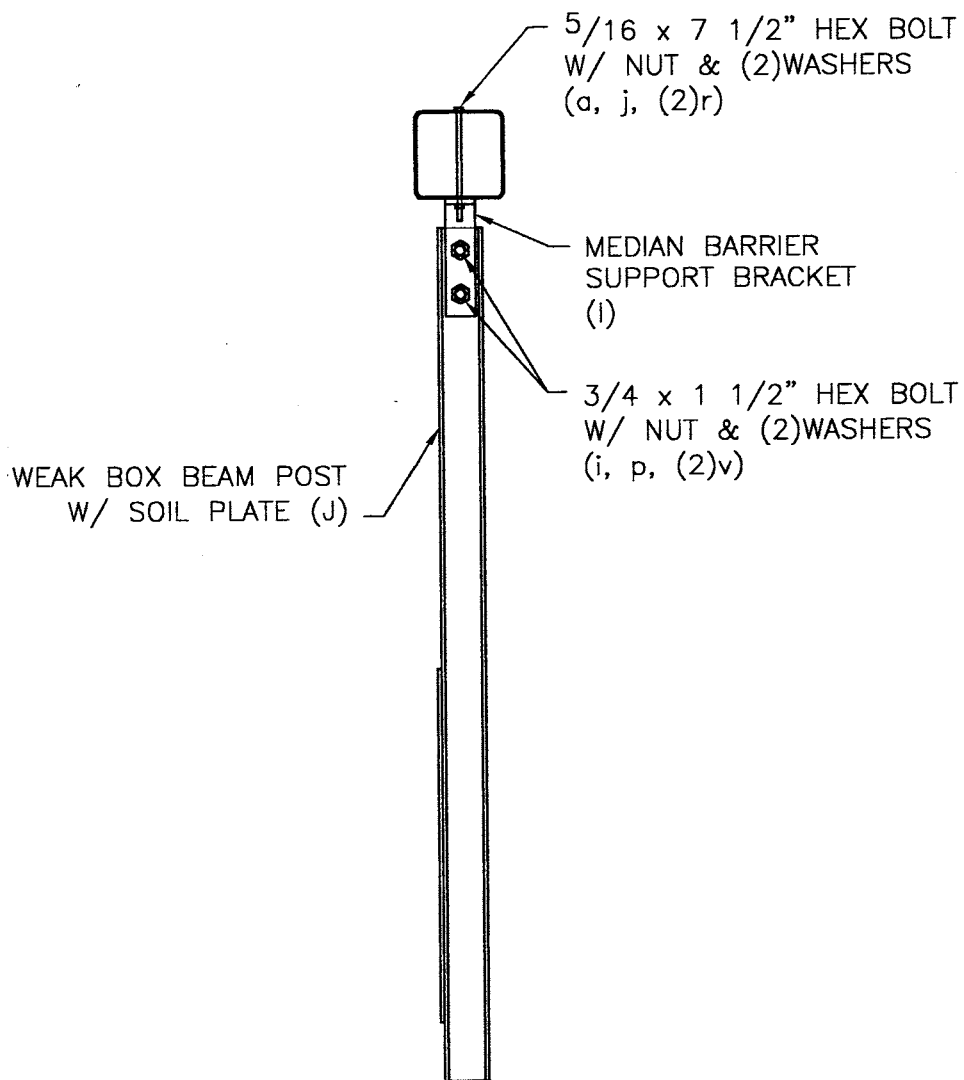

Figure 13. Posts #2 - #5 Connection Detail for the Median BEAT-MT

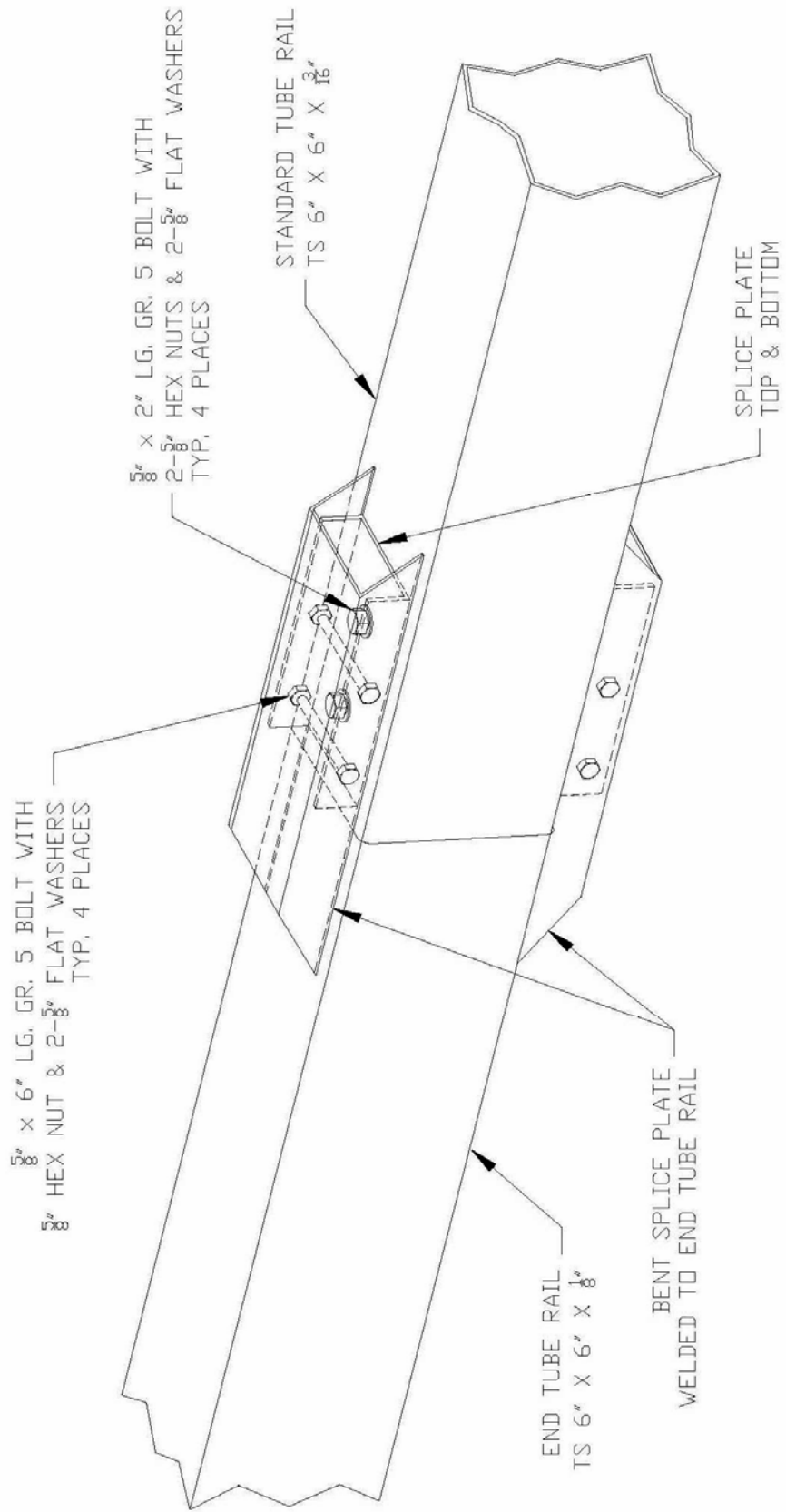

Figure 12a. **Optional** First Rail Tie Plate for the BEAT-MT

## **Install BEAT-MT Impact Head (Same as used in roadside BEAT)**

Place the impact head inside the end tube. The impact head should be positioned so the holes at the end of the tube and the hole in the impact head are aligned. Also be sure the impact head is inserted into the end tube section with the large triangular gusset plates facing down. Attach the end tube to impact head using a 5/16"x 7 1/2" hex bolt, nut and 2 washers. See **Figure 10**.

Note. It is recommended that the front face of the impact head be delineated with an object marker that meets local specifications for better night visibility. However, the impact face object marker is not included as part of the shipped materials for the BEAT-MT unless specifically requested in the contract plans.

## **Install Post Breaker (Same as used in roadside BEAT)**

Attach the post breaker to the reverse direction traffic side of post #1 with a 5/8"x 3" hex bolt, nut and washer and a 1/4"x 3" hex bolt, nut and washer. This will be the side that traffic will be traveling from the downstream 6"x 8" median barrier toward the impact head. See **Figure 10**.

## **Install Tether Cable**

The tether cable will arrive bundled into a "figure-8" with two free ends that each has swaged loops. **DO NOT CUT THE TIE ON THE CABLE.** Attach the shorter free end ( $\approx 28$ " ) to the lower backside of the impact head by putting the end loop through the slot in triangular gusset plates and passing a 1/2"x 5" hex bolt through the loop. Secure the bolt with a nut. Attach the "figure-8" to the back of the impact head using the provided cable ties passing through the upper and lower gusset notches as shown in **Figure 10**. Finally, pass the longer free end of the bundle ( $\approx 50$ " ) above the post-breaker and around post #1. Pass the anchor cable through the end loop prior to attaching the anchor cable through post #1, as shown in **Figure 10**.

## **Install Cable Assembly w/ Bearing Plate (Same as used in roadside BEAT)**

Place the cable assembly through the lug welded to the underside of the end tube near post #2. The other end of the anchor cable will pass through the tether cable loop and through post #1. (See above for tether cable attachment). Place the bearing plate at the base of post #1 with the 5" dimension up and the 3" dimension down. Secure both ends of the cable assembly with a 1" hex nut and washer. While tightening the nuts at the end of the cable, restrain the cable at the end being tightened to avoid twisting the cable.

Upon completion of the installation, the cable should be taut.

## **BEAT and BEAT-MT Installation Inspection Checklist**

State: \_\_\_\_\_

Date: \_\_\_\_\_

Project #: \_\_\_\_\_

Inspection performed by: \_\_\_\_\_

Location: \_\_\_\_\_

- The 6"x 6" end tube section is the special 1/8" thickness tube as supplied by the manufacturer with the corners cut at the approach end where the impact head is placed.
- Both the **Roadside BEAT** terminal and **Median BEAT-MT** terminal have at least one 18'-0" long 6"x 6" x 3/16" standard tube section joining with the special 12'-0" long end tube section.
- The end tube section is bolted to the standard tube section with the special rail tie splice.
- The height of the 6"x 6" box beam tubing is in accordance with the plans:  
--**Roadside BEAT** rail height = 2'-4"  
--**Median BEAT-MT** rail height = 2'-4"
- The 6"x 6" box beam tubing is attached to rail support brackets with proper hardware:  
--**Roadside BEAT** post bolt = 5/16" x 7 1/2" hex bolt  
--**Median BEAT-MT** post bolt = 5/16" x 7 1/2" hex bolt
- The rail support brackets are attached to posts with proper hardware:  
--**Roadside BEAT** posts #1 & #2 support bracket bolts = 1/2"x 2" hex bolt  
--**Median BEAT-MT** posts #2 through #5 support bracket bolts = 3/4"x 1 1/2" hex bolt  
--**Median BEAT-MT** post #1 support bracket bolt = 1/2"x 2" hex bolt
- The upper and lower sections of post #1 are properly connected with a 5/8"x 8" hex bolt.
- The 3" weak posts have the soil plate positioned the same direction as the rail.  
--**Roadside BEAT** has a 3" weak post at post location #2 plus at least three more 3" weak posts spaced at 6'-0" within the standard downstream 6"x 6" box beam barrier.  
--**Median BEAT-MT** has a 3" weak post at post locations #2 through #5.
- The impact head is properly inserted into the end tube section with the large triangular gusset plates facing down. The bottom of the impact head is approx 12" above ground.
- The post breaker is installed on the proper side of post #1 and stabilized with two bolts.
- The 8" x 8" bearing plate at post 1 is correctly positioned with the 5" dimension up & the 3" dimension down. The anchor cable is taut and correctly installed.
- The **Median BEAT-MT** has a tether cable properly attached to restrain the impact head.
- If the posts were augered, be sure the backfill material around the posts is compacted.

Additional notes:

---

---

## Installation Recommendations When Rock is Encountered on the BEAT and BEAT-MT Systems

The following recommended installation procedures are intended for installations where bedrock is encountered at a depth shallower than the eight-foot length post embedment for BEAT post #1. When cobbles or loose rock is encountered that prevents driving the first BEAT post to full depth, it is necessary to auger to full depth or follow the "Alternative Foundation Using Concrete" option shown below. Concrete shall not be used at any other BEAT posts.

In installations where bedrock is encountered at the depths indicated below, it will be necessary to core into the rock for the following depths. This cored hole should be 10" in diameter. The installer should assure that the rock removed out of the cored hole is reasonably solid rock.

<u>Surface of Rock</u>	<u>Required Core Depth Below Rock Surface</u>
0 to 2'	36"
2' to 4'	24"
4' to 7'	12"
7' to 8'	Core to 8'

The post may then be shortened by cutting the bottom of the post. Place granular material in the bottom of the hole so that the base rests 2.5" from the bottom of the cored hole. Cold galvanize paint the cut surfaces.

The post shall be placed in the hole and backfilled with adequately compacted material. If preferred, this post #1 may be backfilled with concrete.

These depths will provide sufficient anchorage to provide system redirection capacity and prevent the post from being pulled vertically from the ground during impact.

### Alternative Foundation Using Concrete

If the BEAT post #1 has reached a minimum depth of 48" and cannot be driven further, the following options may be followed for installation in an augered hole:

<u>Depth of Augered Hole</u>	<u>Diameter of Augered Hole</u>	<u>Concrete Depth</u>
48" to 67"	24" Diameter	Bottom 36" of hole
68" to 95"	12" Diameter	Bottom 24" of hole

